

# brother

## EF4-B531

超高速 2 本針オーバーロックミシン

HIGH SPEED TWIN-NEEDLE OVERLOCK MACHINE

DOPPEL-OVERLOCK-SCHNELLNÄHMASCHINE

MACHINE A DEUX ALGUILLE POUR POINT DE SURETE A HAUTE VITESSE

MAQUINA SOBREORILLADORA RAPIDA CON AGUJA DOBLE

パーツブック

PARTS BOOK

TEILEKATALOG

LIVRE DES PIECES

LIBRO DE REFERENCIA DE PIEZAS

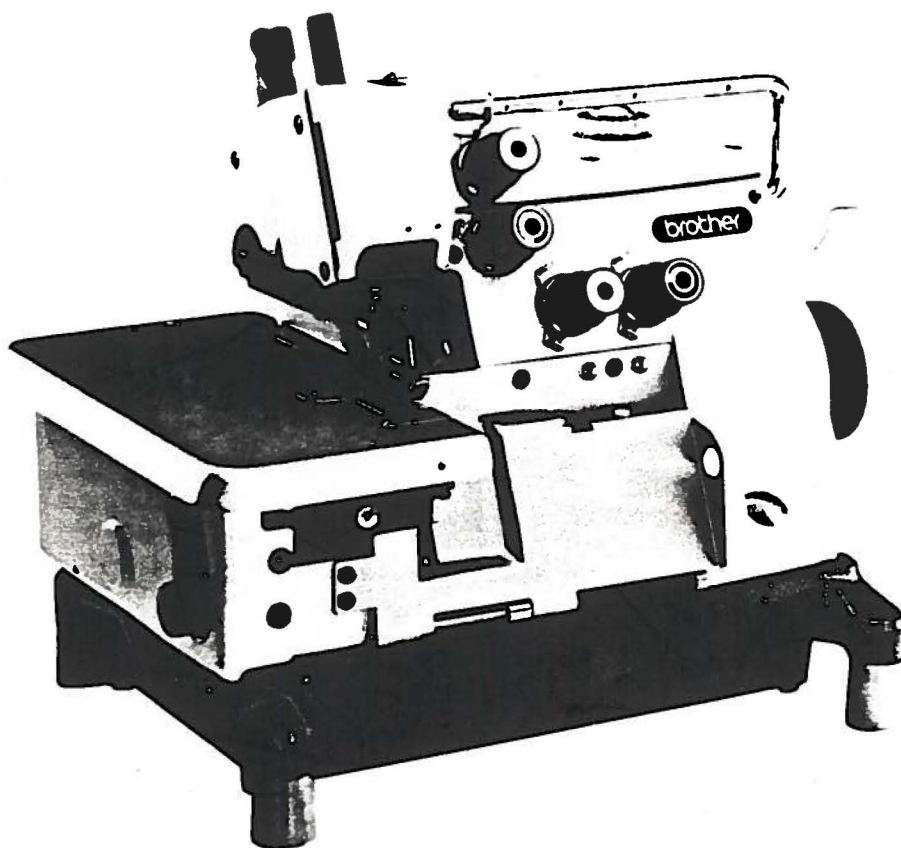

P531801



## パーツブックご利用に際して

1. この本は、この本の表紙（正誤表の挿入されている場合は正誤表）に記載されているものと同じプレートが取り付けられているミシンのためのものです。
2. 標準以外で使用する部品は 

021
000

 で示します。尚実線内の数字はサブクラスを表わしています。
3. RMKS 欄に※印のついている部品は、相手部品との共合せ加工がなされていますので、相手部品と一緒に、ご注文下さい。
4. 組単位で補給する部品は、

--

 破線で示しております。
5. この本は1990年12月のデータに基づいて作成されたものです。
6. 部品は予告なしに設計変更される場合があります。
7. 部品コード欄が\*となっている場合は、ゲージ部品一覧表（47ページ）でお調べ下さい。

## 目 次

A. フレーム関係	2
B. 駆動軸関係	6
C. 針冷却装置	6
D. 針棒関係	8
E. 押エ関係	12
F. 送り関係	20
G. 上メス・下メス関係	24
H. ラフラー装置関係	26
J. ヒモ案内関係	32
K. テープワインダー関係	32
L. ラッパー関係	34
M. バックタック関係	34
N. 上ルーバ関係	36
P. 下ルーバ関係	38
Q. 給油・潤滑関係	40
R. 糸調子関係	42
Z. 付属品関係	44
仕様別部品一覧表	47
ゲージ部品	53
索引	56

## Notes for using this parts book

1. This book is applicable to sewing machines which have the same plate number as shown on the cover of this book (or correction sheet).
2. Non-standard parts are indicated with 

021
000

 .  
Numbers inside the line indicate the subclass.
3. An asterisk ※ in the RMKS indicates a part that is manufactured to fit with a paired part. Be sure to order the pair.
4. Parts supplied as complete assemblies are circled by a dotted line ( ) .
5. This book was prepared based on information available in December 1990.
6. Parts are subject to changes in design without prior notice.
7. If the symbol \* is found in the "Parts No." column, refer to the different parts list on page 47.

## CONTENTS

A . Machine body .....	2
B . Crank shaft mechanism .....	6
C . Needle cooler .....	6
D . Needle bar mechanism .....	8
E . Presser foot mechanism .....	12
F . Feed mechanism .....	20
G . Knife mechanism .....	24
H . Ruffling attachment .....	26
J . Gimp guide mechanism .....	32
K . Tape winder mechanism .....	32
L . Lapper mechanism .....	34
M . Back-tacking .....	34
N . Over looper mechanism .....	36
P . Under looper mechanism .....	38
Q . Lubrication .....	40
R . Thread tension .....	42
Z . Accessories .....	44
DIFFERENT PARTS LIST .....	47
GAUGE PARTS .....	53
INDEX .....	56



## Hinweise Zur Verwendung dieser Teileiste

1. Dieses Buch bezieht sich auf die Nähmaschinen mit derselben Kennungsnummer wie auf diesem Buchumschlag (oder auf dem Korrekturblatt).
2. Die Sonderteile sind mit 

021
000

 bezeichnet.  
Die Nummern im gestrichelten Feld geben die Unterbezeichnung an.
3. Mit einem Asterisk ※ sind Teile bezeichnet, die nur mit anderen Teilen zusammen verwendet werden können. Sie müssen daher alle zusammengehörige Teile miteinander bestellen.
4. Die Teile, die als kompletter Satz geliefert werden, sind mit einer 

--

 gestrichelten Linie umrandet.
5. Dieses Buch basiert auf den Informationen vom Dezember 1990.
6. Modelländerungen sind vorbehalten.
7. Dieses Zeichen \* in der Spalte "Parts No. (Teil-nummer)" verweist auf die Gesonderte Stückliste auf Seite 47.

## INHALTSVERZEICHNIS

A. Maschinengehäuse .....	2
B. Kurbelwelle .....	6
C. Nadelkühlungsvorrichtung .....	6
D. Nadelstangenvorrichtung .....	8
E. Stoffdrückerfuß .....	12
F. Transportvorrichtung .....	20
G. Messer .....	24
H. Kräuselvorrichtung .....	26
J. Schnurführung .....	32
K. Bandaufwickelvorrichtung .....	32
L. Falz-Mechanismus .....	34
M. Rückwärtsheftvorrichtung .....	34
N. Oberen Greifer .....	36
P. Unterer Greifer .....	38
Q. Schmierung .....	40
R. Fadenspannung .....	42
Z. Zubehör .....	44
ZUBEHÖRLISTE .....	47
TEILE DER LEHRE .....	53
VERZEICHNIS .....	56

## Notes sur l'utilisation de ce manuel de pièces détachées

1. Ce manuel est destiné aux machines à coudre ayant le même numéro de plaque montré sur la couverture de ce manuel (ou sur la feuille de corrections).
2. Les pièces non standard sont signalées par l'indication 

021
060

 .  
Les numéros à l'intérieur du cadre en pointillés indique la sous-classe.
3. Un astérisque \* dans le RMKS indique une pièce qui est fabriquée pour correspondre avec une pièce jumelée. S'assurer de commander la pairs.
4. Les pièces fournies en tant qu'assemblages complets sont encadrées avec un trait pointillé (---) .
5. Ce manuel a été fait d'après les renseignements valables au mois de Décembre 1990.
6. Les pièces peuvent être sujettes à des modifications sans préavis.
7. Si le symbole \* se trouve dans la colonne "Parts No. (N° de pièce)" veuillez la vous référer à la liste de pièces annexe page 47.

## TABLE DES MATIERES

A . Corps de la machine .....	2
B . Mécanisme du vilebrequin .....	6
C . Mécanisme du refroidisseur d'aiguille .....	6
D . Mécanisme de la barre à aiguille .....	8
E . Mécanisme du pied presseur .....	12
F . Mécanisme de l'entraînement .....	20
G . Mécanisme du couteau .....	24
H . Accessoire pour fronces .....	26
J . Mécanisme du guide-fil .....	32
K . Mécanisme de l'enrouleur de ruban .....	32
L . Mécanisme à rabat .....	34
M . Point d'arrêt .....	34
N . Mécanisme du boucleur supérieur .....	36
P . Mécanisme du boucleur inférieur .....	38
Q . Lubrification .....	40
R . Tension du fil .....	42
Z . Accessoires .....	44
LISTE DES PIECES ACCESSOIRES .....	47
PIECES DE JAUGE .....	53
INDEX .....	56

## Notas para usar este Manual de Piezas

1. Este libro sirve para todas las máquinas de coser que llevan la misma placa de identificación que la que se puede ver en la tapa de este libro (o en la hoja de erratas).
2. Las piezas no normales aparecen como 

021
000

.  
Los números dentro del rectángulo punteado indican la subclase.
3. Un asterisco \* en el RMKS indica que la pieza forma parte de un par. Se debe hacer el pedido en pares.
4. Las piezas suministradas como conjuntos completos se enmarcan con una línea punteada 

--

.
5. Este libro ha sido compilado basándose en los datos de que se disponía en diciembre 1990.
6. Las piezas quedan sujetas a cambios de diseño sin aviso previo.
7. De haber un símbolo \* junto al "Parts No. (Número de Pieza)", habrá que mirar la lista de piezas separada de la página 47.

## INDICE

A .	Cuerpo de la máquina .....	2
B .	Mecanismo del cigüeñal .....	6
C .	Mecanismo del enfriador de aguja .....	6
D .	Mecanismo del barra de aguja .....	8
E .	Mecanismo del prensa telas .....	12
F .	Mecanismo de la alimentación .....	20
G .	Mecanismo del cuchilla .....	24
H .	Accesorio de fruncido .....	26
J .	Mecanismo guía del hilo .....	32
K .	Mecanismo bobinador de cinta .....	32
L .	Mecanismo de solapado .....	34
M .	Pespunte de revés .....	34
N .	Mecanismo del presilladora superior .....	36
P .	Mecanismo del presilladora inferior .....	38
Q .	Lubricación .....	40
R .	Tension del hilo .....	42
Z .	Accesorios .....	44
	LISTA DE PIEZAS ACCESORIAS .....	47
	PIEZAS DE CALIBRE .....	53
	INDICE .....	56

A. フレーム関係/Machine body/Maschinengehäuse/  
Corps de la machine/Cuerpo de la máquina

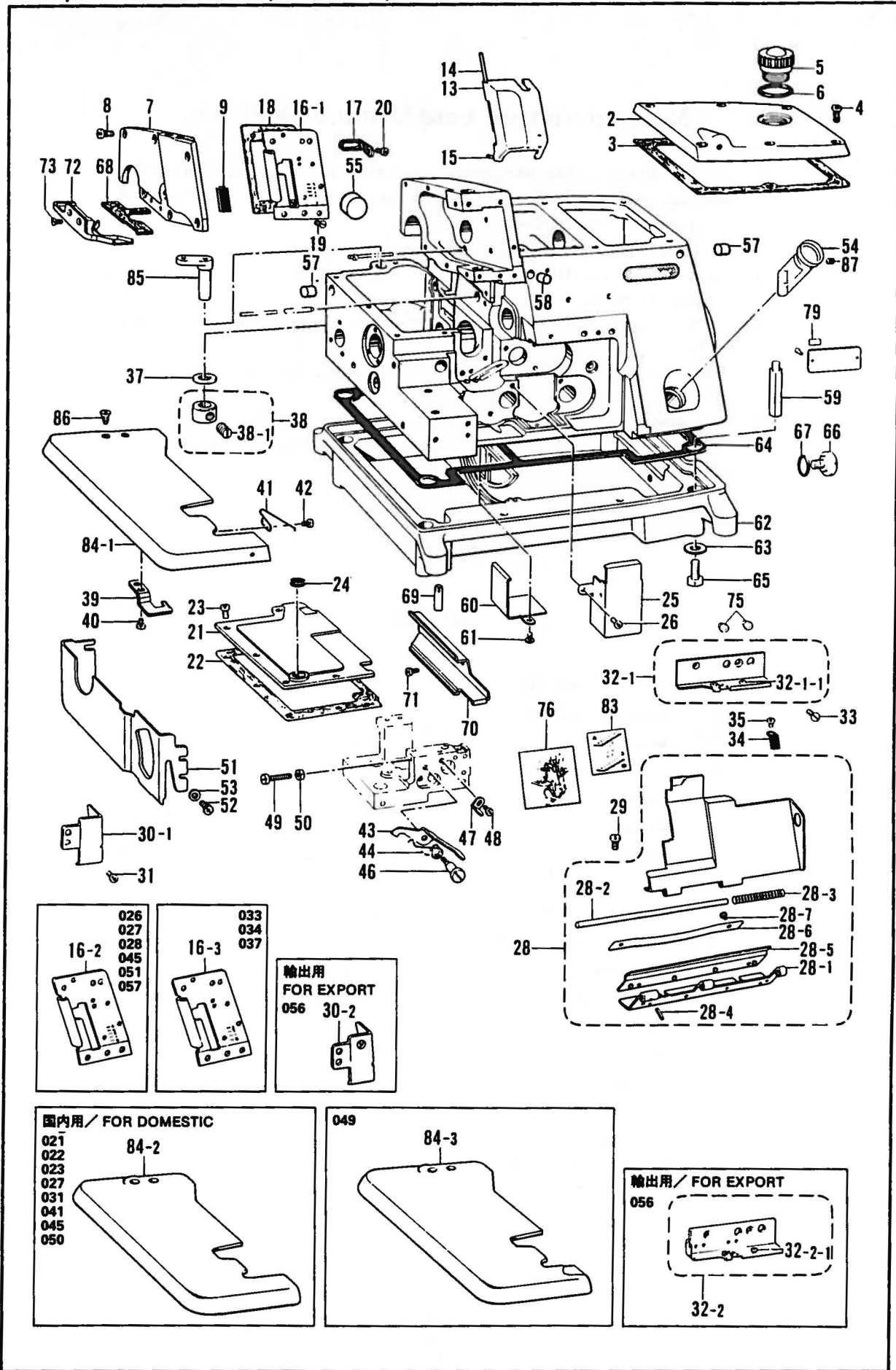



A. フレーム関係/Machine body/Maschinengehäuse/  
Corps de la machine/Cuerpo de la máquina

REF.NO.	CODE	Q'TY	品名	NAME OF PARTS	RMKS
2	146419009	1	ウフカカバー	TOP COVER	
3	146420000	1	ハッソキン	PACKING	
4	062681412	6	ナヘ"コ437-40X14	SCREW 437X14	
5	146421000	1	オイルクチキャップ	OIL FEEDING CAP	
6	113589001	1	オイルマト"ハッソキン	PACKING	
7	146422009	1	ソクメンカバー	COVER FOR NEEDLE DRIVING MECHANISM	
8	062680712	6	ナヘ"コ437-40X7	SCREW 437X7	
9	143992001	1	ゴムフタ	RUBBER CAP	
13	146425009	1	メンイタカバー	FACE PLATE COVER	
14	146426000	1	ピンジ"シツク	PIN FOR FACE PLATE	
15	146427001	1	アナトメネジ"3.18クホ"ミ	SCREW 3.18	
16-1	146428001	1	メンイタクミ<シ"ヌイヨウ>	FACE PLATE <PLAIN STITCHING>	
16-2	146706001	1	メンイタクミ<ハ"ルキ"ヨウ>	FACE PLATE <BULKY>	
16-3	146430001	1	メンイタクミ<ラフラー"ヨウ>	FACE PLATE <RUFFLING>	
17	146432001	1	トメイタハ"ネ	STOPPER SPRING	
18	146433000	1	ハッソキン	FACE PLATE PACKING	
19	102843004	3	サラネジ"3.57	SCREW 3.57	
20	062670612	2	ナヘ"コ357-40X6	SCREW 357X6	
21	146708000	1	オクリダ"イカカバー	COVER FOR FEED MECHANISM	
22	146709000	1	ハッソキン	PACKING	
23	*	5	ナヘ"コ437-40X7	SCREW 437X7	
24	111486001	1	クロスプレートクッション	CLOTH PLATE CUSHION	
25	146436001	1	ウチカバー	INSIDE COVER	
26	062670612	2	ナヘ"コ357-40X6	SCREW 357X6	
28	*	1	マエカバー"クミ	FRONT COVER ASSEMBLY	
28-1	146440001	1	マエカバー"ピンジ"	FRONT COVER HINGE	
28-2	146441000	1	マエカバー"ピンジ"シツク	FRONT COVER HINGE SHAFT	
28-3	146442001	1	マエカバー"ハ"ネ	FRONT COVER SPRING	
28-4	047140842	1	スプリング"ピン1.4X8	SPRING PIN 1.4X8	
28-5	148984001	1	ピンジ"カバー	HINGE COVER	
28-6	152194001	1	ピンジ"カバー"オサエイタ	HINGE COVER PRESSER PLATE	
28-7	062670412	2	ナヘ"コ357-40X4	SCREW 357X4	
29	060680512	2	ハ"イント"437-40X5	SCREW 4.37X5	
30-1	146712001	1	マエカバー"アンナイイタ	FRONT COVER GUIDE PLATE	
30-2	146443001	1	-----	FRONT COVER GUIDE PLATE <BINDING>	
31	062670612	2	ナヘ"コ357-40X6	SCREW 357X6	
32-1	146713001	1	マエカバー"ササエクミ	SUPPORTER FOR FRONT COVER ASSEMBLY	
32-1-1	146924000	2	スレット"フ"ツシユ	THREAD BUSHING	
32-2	147367001	1	-----	SUPPORTER FOR FRONT COVER ASSEMBLY <BINDING>	
32-2-1	146924000	2	-----	THREAD BUSHING	
33	117160001	2	サラネジ"4.37	SCREW 4.37	
34	154829001	1	マエカバー"トメイタハ"ネ	STOPPER SPRING FOR FRONT COVER	
35	123185001	1	マルヒラネジ"3.57X4.5	SCREW 3.57X4.5	
37	141183000	1	クロスプレートシート	CLOTH PLATE SEAT	
38	181969003	1	セツトカラー"クミ	SET COLLAR ASSEMBLY	
38-1	101706001	2	トメネジ"6.35	SCREW 6.35	
39	146449001	1	クロスプレートトメイタ	CLOTH PLATE SUPPORTER	
40	060670512	2	ハ"イント"357-40X5	SCREW 357X5	
41	146450001	1	クロスプレートモト"シハ"ネ	SPRING	
42	060670512	1	ハ"イント"357-40X5	SCREW 357X5	
43	146451001	1	クロスプレートトメテコ	CLOTH PLATE LEVER	
44	146452001	1	トメテコモト"シハ"ネ	SPRING	
46	146453001	1	タ"ンネジ"3.57	STUD SCREW 3.57	
47	146454001	1	トメテコストツハ"	CLOTH PLATE LEVER STOPPER	
48	062670612	1	ナヘ"コ357-40X6	SCREW 357X6	
49	062671412	1	ナヘ"コ357-40X14	SCREW 357X14	
50	021670202	1	ナツト2シユ3.57	NUT 3.57	
51	146717109	1	クロスプレートシタ	CLOTH PLATE (LOWER)	
52	062680712	4	ナヘ"コ437-40X7	SCREW 437X7	
53	100645003	4	サ"カ"ネ	WASHER	
54	148084001	1	オイルゲ"ー"シ"マト"	OIL GAUGE WINDOW	

A. フレーム関係 / Machine body / Maschinengehäuse /  
 Corps de la machine / Cuerpo de la máquina

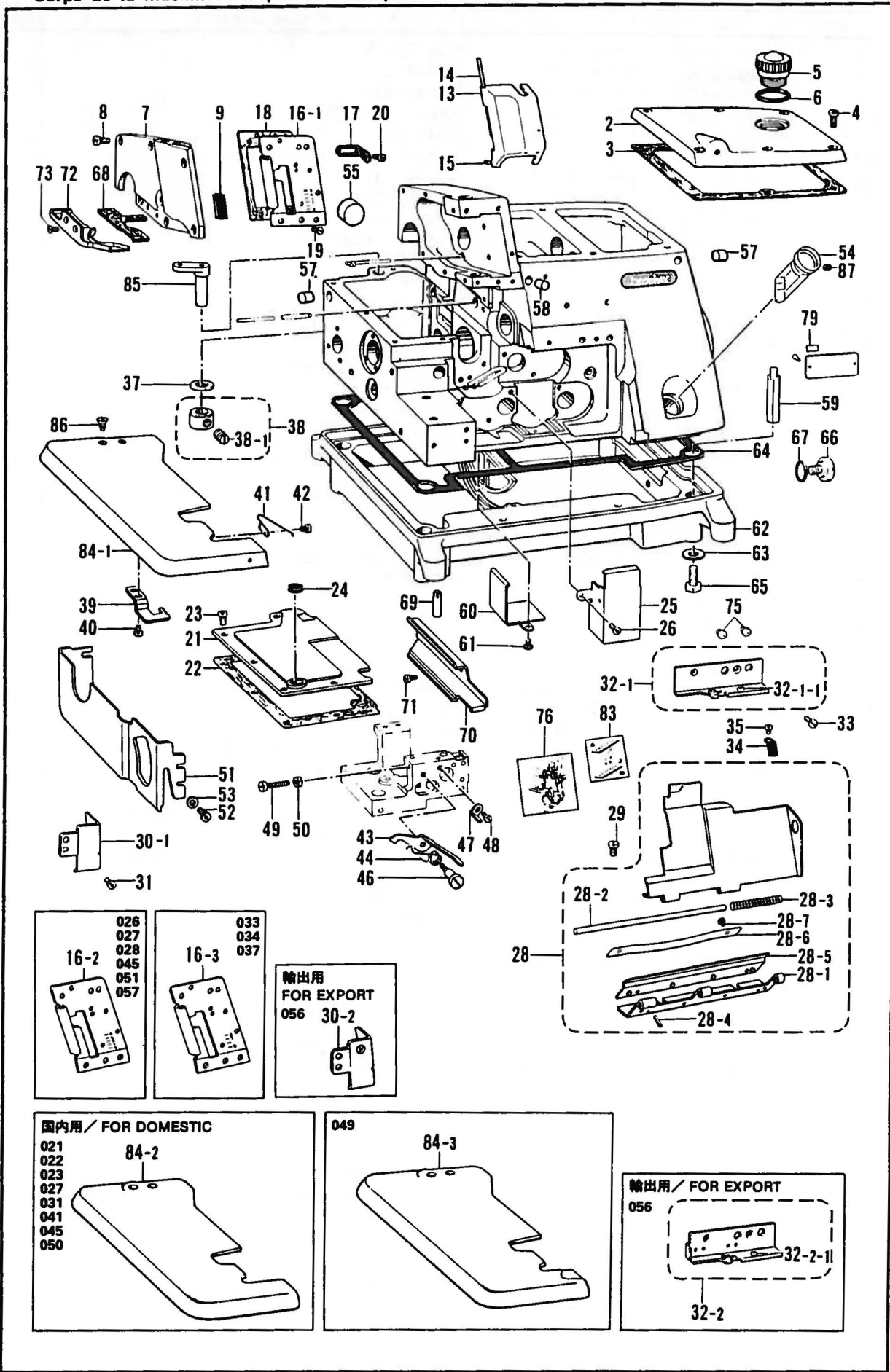



A. フレーム関係/Machine body/Maschinengehäuse/  
Corps de la machine/Cuerpo de la máquina

REF NO	CODE	Q'TY	ヒンメイ	NAME OF PARTS	RMKS
55	140066009	1	メクラセン	OIL CAP	
57	146315009	2	メクラセン	OIL CAP	
58	140421009	1	メクラセン	OIL CAP	
59	151059001	4	ホンタイシチユウ	MACHINE BODY LEG	
60	146457001	1	シキリイタ	OIL STOPPER PLATE	
61	062670612	2	ナヘ"コ357-40X6	SCREW 357X6	
62	S03887209	1	アブ"ラウケ	OIL RESERVOIR	
63	159476000	4	サ"カ"ネ	WASHER	
64	151060000	1	ハ"ツキン	PACKING	
65	017771612	4	ボ"ルト6.35X16	BOLT 6.35X16	
66	110641002	1	タ"ンネシ"9.52	STUD SCREW 9.52	
67	109203001	1	Oリング"	O RING	
68	159640000	1	フェルト	FELT	
69	118550001	4	ミゾ"ツキピン	DOWEL PIN	
70	146460001	1	クロスプレートヌノアンナイL	CLOTH GUIDE (LARGE)	
71	062670612	2	ナヘ"コ357-40X6	SCREW 357X6	
72	159639001	1	クロスプレートヌノアンナイS	CLOTH GUIDE (SMALL)	
73	108960002	2	サラネシ"3.57	SCREW 3.57	
75	*	2	オイルニガ"シク"チ	OIL HOLE BOLT FOR OIL GAUGE	
76	146765001	1	イトオシセツメイイタ	THREADING DIAGRAM	
79	*	1	シヨウラヘ"ル	LABEL	
83	147943001	1	ルーハ"イトチヨウセツラヘ"ル	LABEL	
84-1	S09323001	1	クロスプレート	CLOTH PLATE	
84-2	S09324001	1	クロスプレート	-----	
84-3	S11101001	1	クロスプレート	CLOTH PLATE	
85	143374001	1	クロスプレートササエシ"ク	CLOTH PLATE SUPPORTER SHAFT	
86	100032003	2	サラネシ"4.37	SCREW 4.37	
87	014680422	1	アナトメネシ"4.37クホ"ミ	SCREW 4.37	

**B. 駆動軸関係/Crank shaft mechanism/Kurbelwelle/  
Mécanisme du vilebrequin/Mecanismo del cigüeñal**

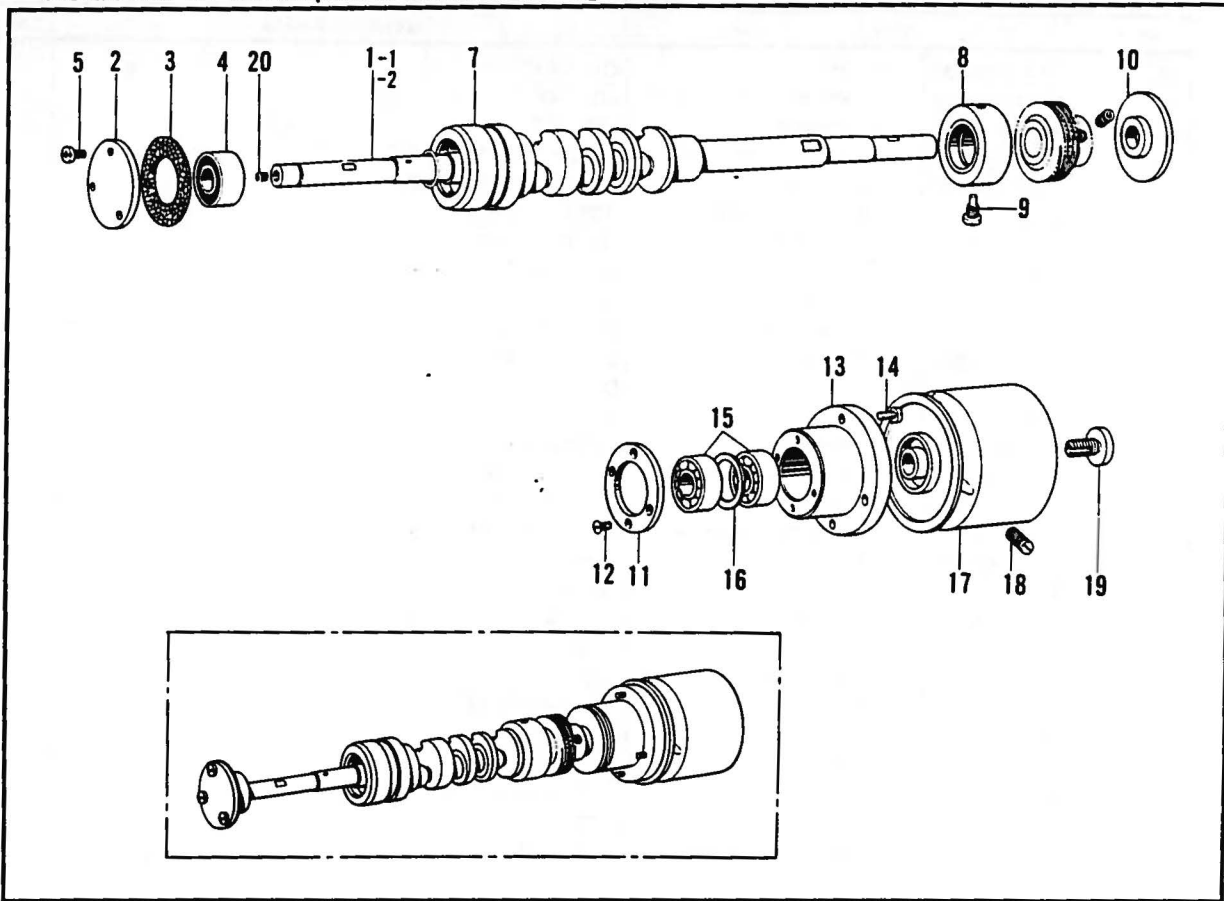

**C. 針冷却装置/Needle cooler/Nadelkühlungsvorrichtung/  
Mécanisme du refroidisseur d'aiguille/Mecanismo del enfriador de aguja**

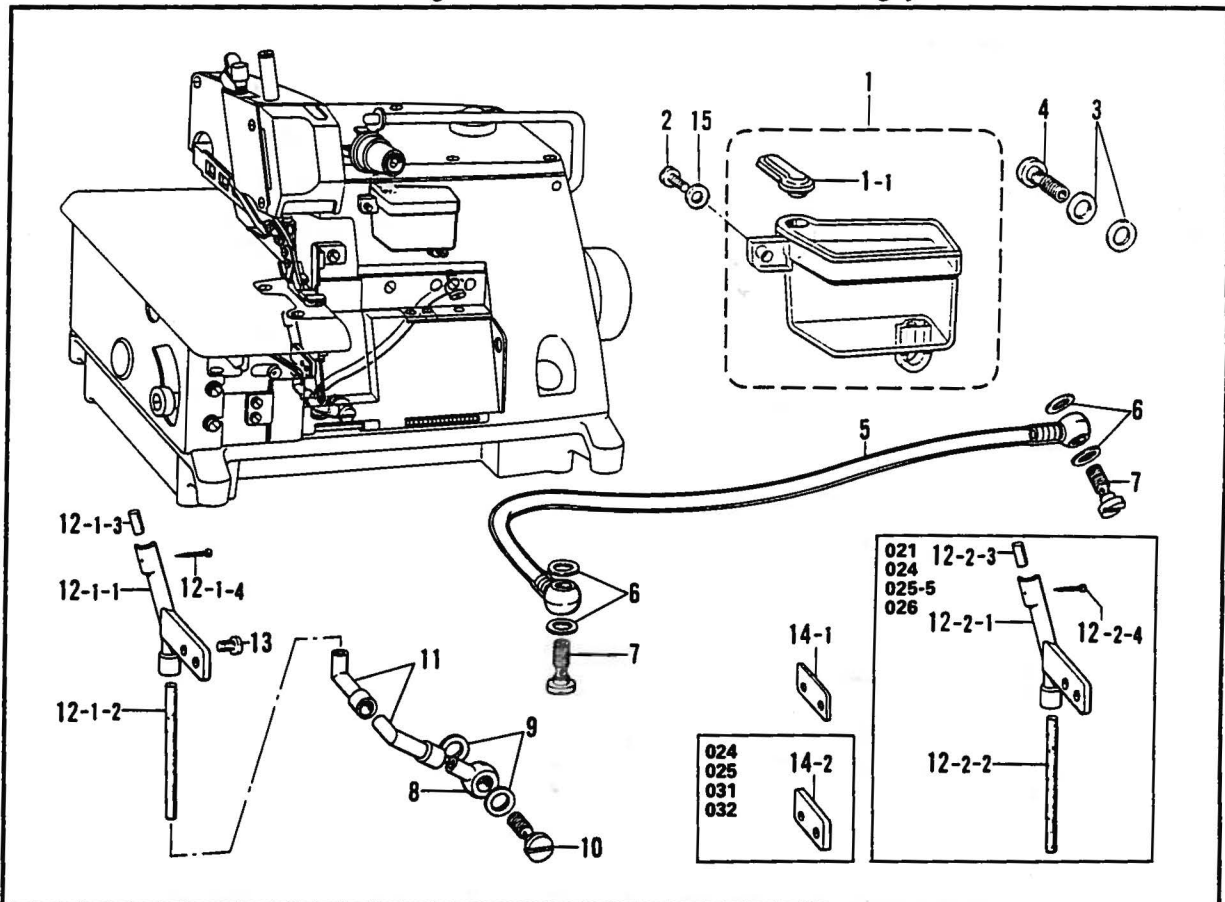

**B. 駆動軸関係/Crank shaft mechanism/Kurbelwelle/  
Mécanisme du vilebrequin/Mecanismo del cigüeñal**

REF.NO.	CODE	QTY	ヒンメイ	NAME OF PARTS	RMKS
1-1	146724001	1	クト"ウジ"クA	CRANK SHAFT (A)	※
1-2	150866001	1	-----	CRANK SHAFT (B) <051,057>	※
2	143311001	1	へ"アリング"フタ	BEARING CAP	
3	143312000	1	へ"アリング"フタハ"ツキン	BEARING CAP PACKING	
4	072600000	1	タマシ"クウケ6000	BEARING 6000	
5	062670812	3	ナヘ"コ357-40X8	SCREW 357X8	
7	146473001	1	クト"ウジ"クメタルLクミ	CRANK SHAFT BUSHING (LEFT) ASSEMBLY	
8	143179000	1	クト"ウジ"クメタルMクミ	CRANK SHAFT BUSHING (MIDDLE) ASSEMBLY	
9	110668001	1	シメネシ"4.76	SCREW 4.76	
10	140084000	1	オイルキリ	OIL REJECTOR	
11	110673000	1	へ"アリング"フタ	BEARING COVER	
12	107244001	4	サラネシ"3.18	SCREW 3.18	
13	110670000	1	へ"アリング"ケース	BEARING CASE	
14	062681012	4	ナヘ"コ437-40X10	SCREW 437X10	
15	072600100	2	タマシ"クウケ6001	BEARING 6001	
16	110672000	1	へ"アリング"カラー	BEARING COVER	
17	147848109	1	プーリー	PULLEY	
18	013761410	2	トメネシ"5.95クホ"ミ	SCREW 5.95	
19	140180001	1	プーリオサエネシ"	CAP SCREW	
20	142274009	1	メクラセン	OIL CAP	
* クドウジクAクミ (B-1-1, D-1, N-1, P-1) 146915-001				* Crank Shaft (A) Assembly (B-1-1, D-1, N-1, P-1) 146915-001	
				* Crank Shaft (B) Assembly (B-1-2, D-1, O-1, R-1) 150874-001	

**C. 針冷却装置/Needle cooler/Nadelkühlungsvorrichtung/  
Mécanisme du refroidisseur d'aiguille/Mecanismo del enfriador de aguja**

REF.NO.	CODE	QTY	ヒンメイ	NAME OF PARTS	RMKS
1	146511100	1	エキレイタンククミ	SILICONE OIL TANK ASSEMBLY	
1-1	154928000	1	ハライトレイキヤクタンクフタ	NEEDLE THREAD COOLER TANK COVER	
2	062681012	1	ナヘ"コ437-40X10	SCREW 437X10	
3	112348001	2	ハ"ツキン	PACKING	
4	112359001	1	ハイユハイフ"ツキ"テネシ"	SCREW	
5	146512101	1	ビニルチューブ"クミ	VINYL TUBE ASSEMBLY	
6	112348001	4	ハ"ツキン	PACKING	
7	112359001	2	ハイユハイフ"ツキ"テネシ"	SCREW	
8	146515000	1	ハイユハイフ"ツキ"テ	OIL FEEDING CONNECTOR	
9	112348001	2	ハ"ツキン	PACKING	
10	112359001	1	ハイユハイフ"ツキ"テネシ"	SCREW	
11	146516000	2	ハイフ"シ"ヨイント	PIPE JOINT	
12-1	146738000	1	フェルトササエクミ	FELT HOLDER ASSEMBLY	
12-1-1	146739000	1	フェルトササエ	FELT HOLDER	
12-1-2	144116000	1	フェルト	FELT	
12-1-3	146740000	1	フェルトS	FELT (SMALL)	
12-1-4	S02874001	1	ムシピン	PIN	
12-2	148008000	1	フェルトササエクミ	FELT HOLDER ASSEMBLY	
12-2-1	148009000	1	フェルトササエ	FELT HOLDER	
12-2-2	144116000	1	フェルト	FELT	
12-2-3	146740000	1	フェルトS	FELT (SMALL)	
12-2-4	S02874001	1	ムシピン	PIN	
13	105216001	2	シメネシ"3.57	SCREW 3.57	
14-1	146787001	1	スヘ"サ (2MMヨウ)	SPACER (2MM)	
14-2	146788001	1	スヘ"サ (3MMヨウ)	SPACER (3MM)	
15	100645003	1	サ"カ"ネ	WASHER	



D. 針棒關係 / Needle bar mechanism / Nadelstangenvorrichtung /  
 Mécanisme de la barre à aiguille / Mecanismo del barra de aguja

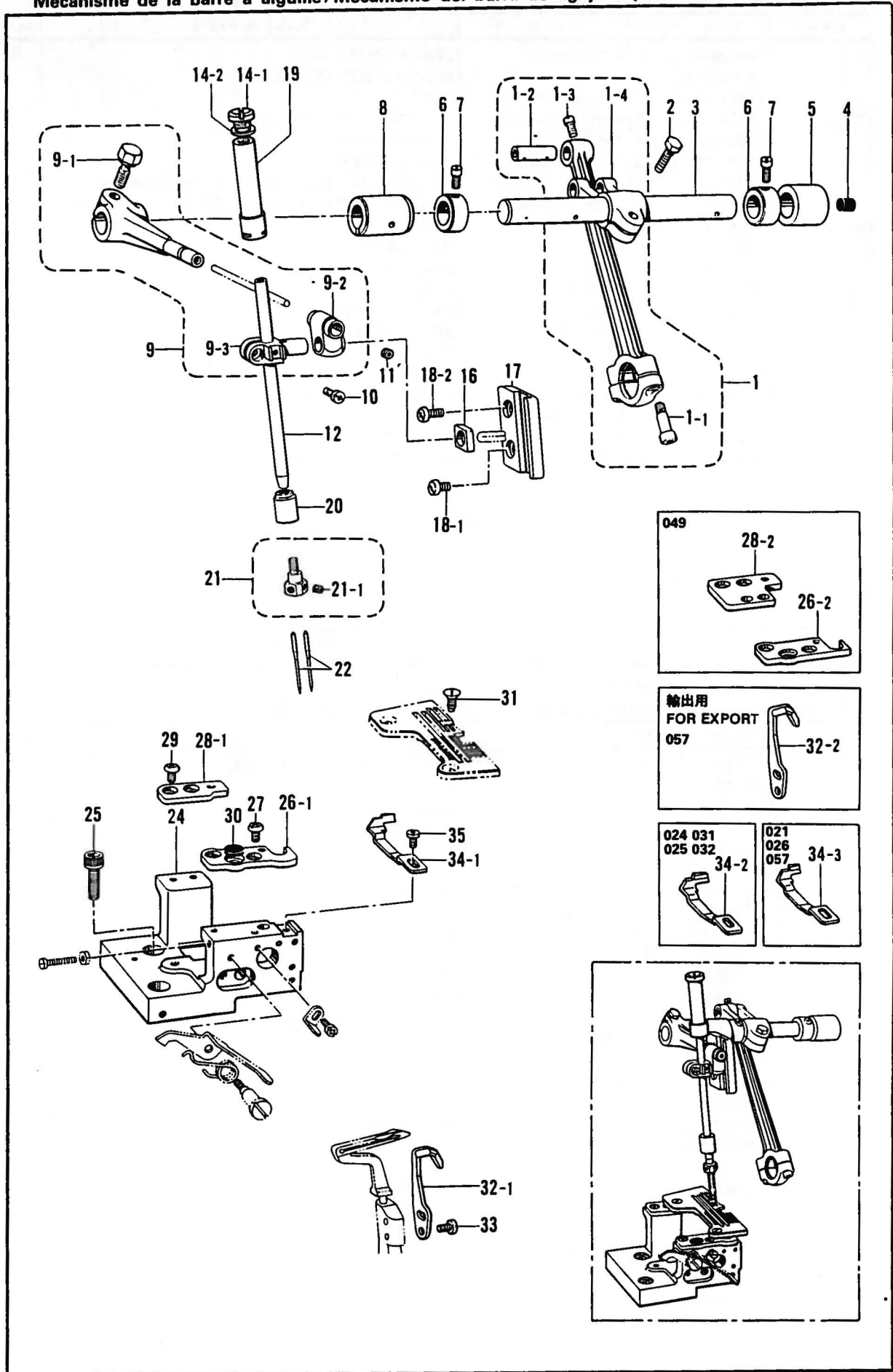



D. 針棒関係/Needle bar mechanism/Nadelstangenvorrichtung/  
Mécánisme de la barre à aiguille/Mecanismo del barra de aguja

REF NO.	CODE	Q'TY	ヒンメイ	NAME OF PARTS	RMKS
1	146476101	1	ハリホ"ウクランクロツト"クミ	NEEDLE BAR DRIVING CRANK ROD ASSEMBLY	※
1-1	148425001	2	アナホ"ルト4.37X14	BOLT 4.37X14	
1-2	140088001	1	クランクロツト"ヒン	PIN	
1-3	100366001	1	マルヒラトメネシ"4.37	SCREW 4.37	
1-4	146478001	1	ハリホ"ウクランクシ"クウチ"	NEEDLE BAR DRIVING LEVER	
2	017771612	1	ホ"ルト6.35X16	BOLT 6.35X16	
3	146479001	1	ハリホ"ウクランクシ"ク	NEEDLE BAR CRANK SHAFT	
4	140327001	1	ゴムセン	OIL CAP	
5	140091000	1	クランクシ"クメタルR	NEEDLE SHAFT BUSHING (RIGHT)	
6	140092001	2	セツトカラー	SET COLLAR	
7	100366001	4	マルヒラトメネシ"4.37	SCREW 4.37	
8	140093000	1	クランクシ"クメタルL	NEEDLE SHAFT BUSHING (LEFT)	
9	146480001	1	ハリホ"ウタ"キクミ	NEEDLE BAR CLAMP ASSEMBLY	
9-1	149170001	1	ホ"ルト6.35X16	BOLT 6.35X16	
9-2	140096001	1	ハリホ"ウツキ"テ	NEEDLE BAR CONNECTOR	
9-3	146482001	1	ハリホ"ウタ"キ	NEEDLE BAR CLAMP	
10	062670812	1	ナヘ"コ357-40X8	SCREW 357X8	
11	146427001	1	アナトメネシ"3.18クホ"ミ	SCREW 3.18	
12	146483001	1	ハリホ"ウ	NEEDLE BAR	
14	S01652001	1	シメネシ"クミ	SCREW ASSEMBLY	
14-1	S00049001	1	シメネシ"8.73	SCREW 8.73	
14-2	S01654000	1	ハ"ツキン	PACKING	
16	159638001	1	ハリホ"ウアンナイカクコマ	NEEDLE BAR GUIDE SLIDE BLOCK	
17	105079001	1	ハリホ"ウアンナイ	NEEDLE BAR GUIDE	
18-1	062680712	1	ナヘ"コ437-40X7	SCREW 437X7	
18-2	S10774001	1	ナヘ"コ437-40X7	SCREW 437X7	
19	S01417001	1	ハリホ"ウメタルU	NEEDLE BAR BUSHING (UPPER)	
20	159636000	1	ハリホ"ウメタルD	NEEDLE BAR BUSHING (LOWER)	
21	*	1	ハリト"メクミ	NEEDLE CLAMP ASSEMBLY	
21-1	146427001	2	アナトメネシ"3.18クホ"ミ	SCREW 3.18	
22	*	2	ミシンハリ	NEEDLE	
24	146725002	1	ハリイタササエイタ"イ	NEEDLE PLATE SUPPORT BRACKET	
25	018061622	2	アナホ"ルト6X16	BOLT 6X16	
26-1	146494001	1	ハリイタササエイタF	NEEDLE PLATE SUPPORTER (FRONT)	
26-2	S09240001	1	ハリイタササエイタF <ハ"ツクタツクヨウ>	NEEDLE PLATE SUPPORTER (FRONT) <BACK-TACKING>	
27	060680512	2	ハ"イント"437-40X5	SCREW 437X5	
28-1	146495001	1	ハリイタササエイタB	NEEDLE PLATE SUPPORTER (REAR)	
28-2	S11109001	1	ハリイタササエイタB <ハ"ツクタツクヨウ>	NEEDLE PLATE SUPPORTER (REAR) <BACK-TACKING>	
29	060680512	2	ハ"イント"437-40X5	SCREW 437X5	
30	111486001	1	クロスフ"レートクツシヨシ	CLOTH PLATE CUSHION	
31	100032003	2	サラネシ"4.37	SCREW 4.37	
32-1	144127001	1	イト"ウハリウケA	MOVABLE NEEDLE GUARD (A)	
32-2	S01471001	1	-----	MOVABLE NEEDLE GUARD (C)	
33	062670812	2	ナヘ"コ357-40X8	SCREW 357X8	
34-1	146777201	1	ハリウケF(2.2MM)	NEEDLE GUARD (FRONT)(2.2MM)	
34-2	146778101	1	ハリウケF(3MM)	NEEDLE GUARD (FRONT)(3MM)	
34-3	S16176001	1	ハリウケF(1.8,2.5MM)	NEEDLE GUARD (FRONT)(1.8,2.5MM)	
35	062670612	1	ナヘ"コ357-40X6	SCREW 357X6	

※クドウジクAクミ (B-1-1, D-1, N-1, P-1) 146915-001

※Crank Shaft (A) Assembly (B-1-1, D-1, O-1, R-1) 146915-001  
※Crank Shaft (B) Assembly (B-1-2, D-1, O-1, R-1) 150874-001

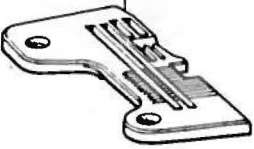
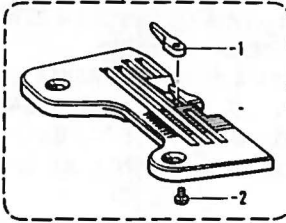
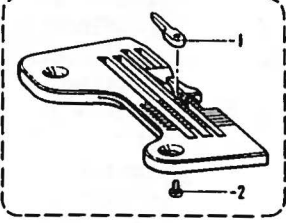
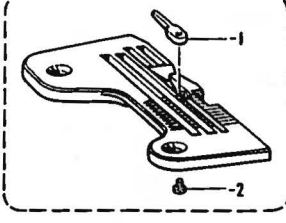
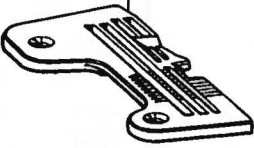
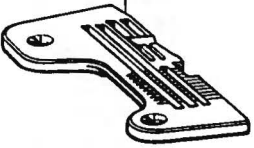
D. 針桿關係/Needle bar mechanism/Nadelstangenvorrichtung/  
 Mécanisme de la barre à aiguille/Mecanismo del barra de aguja

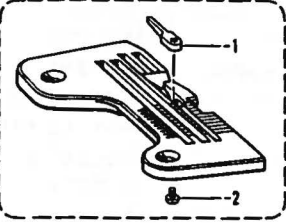
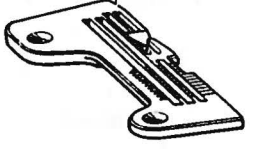
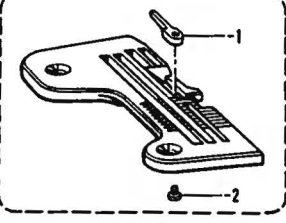
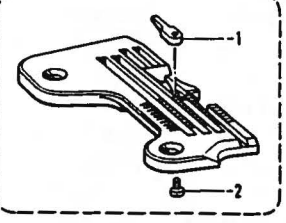
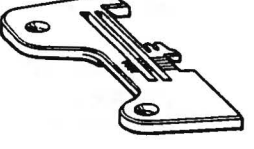
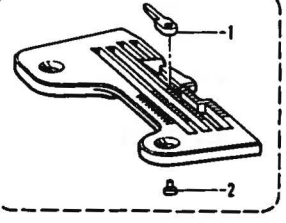
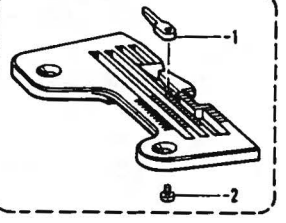
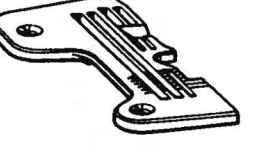
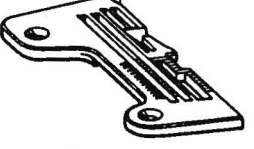
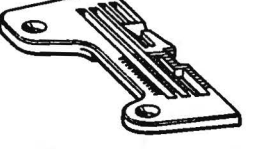
<p>021 026</p> <p>36-1</p> 	<p>022-4</p> <p>36-2</p> 	<p>022-5 023-5 027-5 041-5 045-5</p> <p>36-3</p> 
<p>022-6 023-6 027-6 028-6 045-6</p> <p>36-4</p> 	<p>024-5 025-5</p> <p>36-5</p> 	<p>024-6 025-6</p> <p>36-6</p> 
<p>025-7</p> <p>36-7</p> 	<p>022-7 027-7 028-7 045-7</p> <p>36-8</p> 	<p>031 032</p> <p>36-9</p> 
<p>033-5 034-5 037-5</p> <p>36-10</p> 	<p>049</p> <p>36-11</p> 	<p>050</p> <p>36-12</p> 
<p>051-6</p> <p>36-13</p> 	<p>051-7</p> <p>36-14</p> 	<p>056-6</p> <p>36-15</p> 
<p>057-6</p> <p>36-16</p> 	<p>057-7</p> <p>36-17</p> 	



D. 針棒関係/Needle bar mechanism/Nadelstangenvorrichtung/  
 Mécanisme de la barre à aiguille/Mecanismo del barra de aguja

REF.NO.	CODE	QTY	品名	NAME OF PARTS	RMKS
36-1	146779001	1	ハリイタ <021>	NEEDLE PLATE <021.026>	
36-2	S09133001	1	-----	NEEDLE PLATE ASSEMBLY <022-4>	
36-2-1	S01706001	1	-----	STITCH TONGUE	
36-2-2	S01708001	1	-----	SCREW 1.98	
36-3	S01711001	1	ハリイタクミ 022.041,045/-5>	NEEDLE PLATE ASSEMBLY <022.023,027,041,045/-5>	
36-3-1	S01706001	1	ナカツメ	STITCH TONGUE	
36-3-2	S01708001	1	シメネジ"1.98	SCREW 1.98	
36-4	S01713001	1	ハリイタクミ<022,023, 027,045/-6>	NEEDLE PLATE ASSEMBLY <022,023,027,028,045/-6>	
36-4-1	S01706001	1	ナカツメ	STITCH TONGUE	
36-4-2	S01708001	1	シメネジ"1.98	SCREW 1.98	
36-5	148030001	1	-----	NEEDLE PLATE <024,025/-5>	
36-6	148031001	1	-----	NEEDLE PLATE <024,025/-6>	
36-7	148032001	1	-----	NEEDLE PLATE <025-7>	
36-8	S01715001	1	-----	NEEDLE PLATE ASSEMBLY <022,027,028,045/-7>	
36-8-1	S01706001	1	-----	STITCH TONGUE	
36-8-2	S01708001	1	-----	SCREW 1.98	
36-9	146785001	1	ハリイタ <031>	NEEDLE PLATE <031.032>	
36-10	S01717001	1	ハリイタクミ <033,037/-5>	NEEDLE PLATE ASSEMBLY <033,034,037/-5>	
36-10-1	S01706001	1	ナカツメ	STITCH TONGUE	
36-10-2	S01708001	1	シメネジ"1.98	SCREW 1.98	
36-11	S11110001	1	ハリイタクミ<049>	NEEDLE PLATE ASSEMBLY <049>	
36-11-1	S11111001	1	ナカツメ	STITCH TONGUE	
36-11-2	S01708001	1	シメネジ"1.98	SCREW 1.98	
36-12	149192001	1	ハリイタ <050>	-----	
36-13	S01719001	1	-----	NEEDLE PLATE ASSEMBLY <051-6>	
36-13-1	S01707001	1	-----	STITCH TONGUE	
36-13-2	S01708001	1	-----	SCREW 1.98	
36-14	S01721001	1	-----	NEEDLE PLATE ASSEMBLY <051-7>	
36-14-1	S01707001	1	-----	STITCH TONGUE	
36-14-2	S01708001	1	-----	SCREW 1.98	
36-15	156191001	1	-----	NEEDLE PLATE <056-6>	
36-16	S05837001	1	-----	NEEDLE PLATE <057-6>	
36-17	S05838001	1	-----	NEEDLE PLATE <057-7>	

E. 押工関係/Presser foot mechanism/Stoffdrückerfuß/  
 Mécanisme du pied presseur/Mecanismo del prensa telas

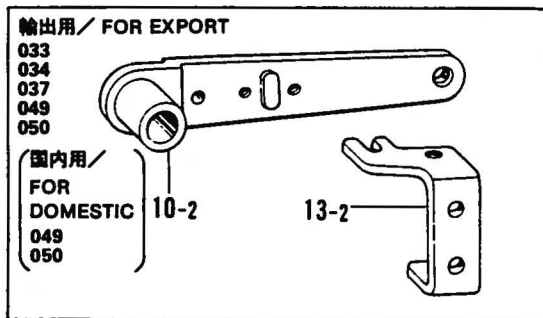
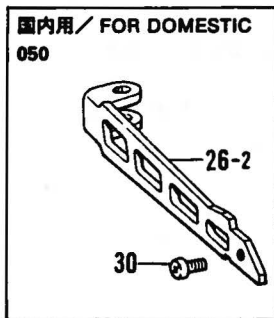
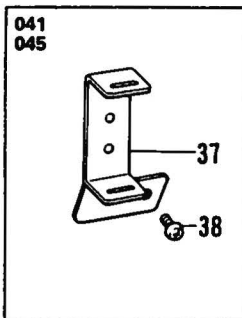
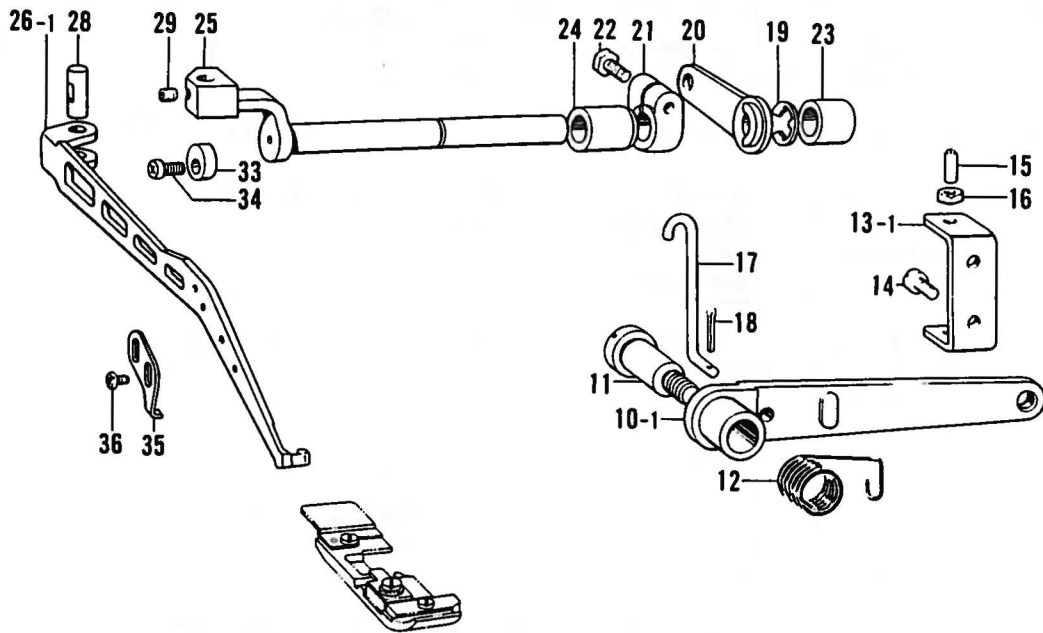
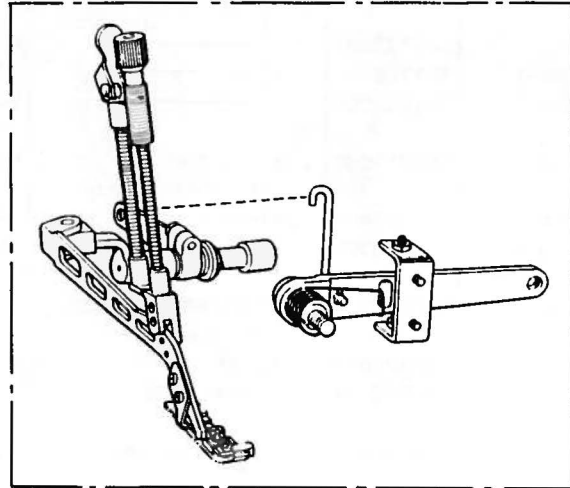
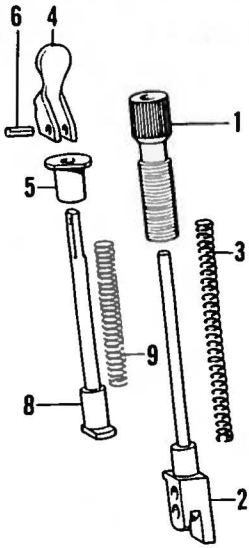

E. 押工関係/Presser foot mechanism/Stoffdrückerfuß/  
Mécánisme du pied presseur/Mecanismo del prensa telas

REF NO	CODE	Q'TY	ヒンメイ	NAME OF PARTS	RMKS
1	144079001	1	オサエチヨウセツネジ"	PRESSER ADJUSTING SCREW	
2	146521001	1	オサエホ"ウ	PRESSER BAR	
3	144081001	1	オサエハ"ネ	PRESSER SPRING	
4	S06561001	1	オサエテアケ"	PRESSER BAR LIFTER	
5	144083001	1	オサエテアケ"サ"	PRESSER BAR LIFTER BASE	
6	047300842	1	スプリング"ヒンAW3	SPRING PIN AW3	
8	144085001	1	オサエホ"ウアケ"	PRESSER BAR LIFTER SHAFT	
9	144086001	1	オサエホ"ウアケ"ハ"ネ	PRESSER BAR LIFTER SPRING	
10-1	143323103	1	オサエアシアケ"レハ"ー	PRESSER FOOT LIFTER LEVER	
10-2	148369101	1	オサエアシアケ"レハ"ー	PRESSER FOOT LIFTER LEVER	
11	148372001	1	タ"ンネジ"7.94	STUD SCREW 7.94	
12	143325001	1	オサエアシアケ"レハ"ーハ"ネ	SPRING	
13-1	146522001	1	レハ"ーチヨウセツイタ	LEVER ADJUSTER PLATE	
13-2	147454001	1	レハ"ーチヨウセツイタ	LEVER ADJUSTER PLATE	
14	062680712	2	ナヘ"コ437-40X7	SCREW 437X7	
15	153483001	2	トメネジ"4.76	SCREW 4.76	
16	110161006	2	ナツト4.76	NUT 4.76	
17	146523001	1	オサエアケ"リンク	PRESSER FOOT LIFTER LINK	
18	110793001	1	フリヒ"ン	PIN	
19	048080342	1	トメフE8	STOP RING E8	
20	146524001	1	オサエアシアケ"MLレハ"ー	PRESSER FOOT LIFTER INSIDE LEVER	
21	140261001	1	セツトカラ"ー	SET COLLAR	
22	017771612	1	ボ"ルト6.35X16	BOLT 6.35X16	
23	140262000	1	オサエウテ"シ"クメタルR	PRESSER ARM SHAFT BUSHING (RIGHT)	
24	140263000	1	オサエウテ"シ"クメタルL	PRESSER ARM SHAFT BUSHING (LEFT)	
25	146525001	1	オサエウテ"シ"ク	PRESSER ARM SHAFT	
26-1	146789001	1	オサエウテ"	PRESSER ARM	
26-2	146526001	1	シユオサエウテ"	-----	
			<ハ"イヒ"ンク"ヨウ>	-----	
28	146527001	1	オサエウテ"ヒ"ン	PIN FOR PRESSER ARM SHAFT	
29	014680422	1	アナトメネジ"4.37クホ"ミ	SCREW 4.37	
30	062680712	1	ナヘ"コ437-40X7	-----	
			<ハ"イヒ"ンク"ヨウ>	-----	
33	S03321001	1	オサエウテ"ストッパ"	PRESSER ARM STOPPER	
34	062711012	1	ナヘ"コ476-32X10	SCREW 476X10	
35	140504001	1	オサエストッパ"	PRESSER FOOT STOPPER	
36	060660512	2	ハ"イント"318-40X5	SCREW 318X5	
37	146883001	1	テーフ"アンナイ	TAPE GUIDE	
			<テーフ"ツケヨウ>	<TAPING>	
38	062660412	2	ナヘ"コ318-40X4	SCREW 318X4	
			<テーフ"ツケヨウ>	<TAPING>	

E. 押工関係/Presser foot mechanism/Stoffdrückerfuß/  
 Mécanisme du pied presseur/Mecanismo del prensa telas

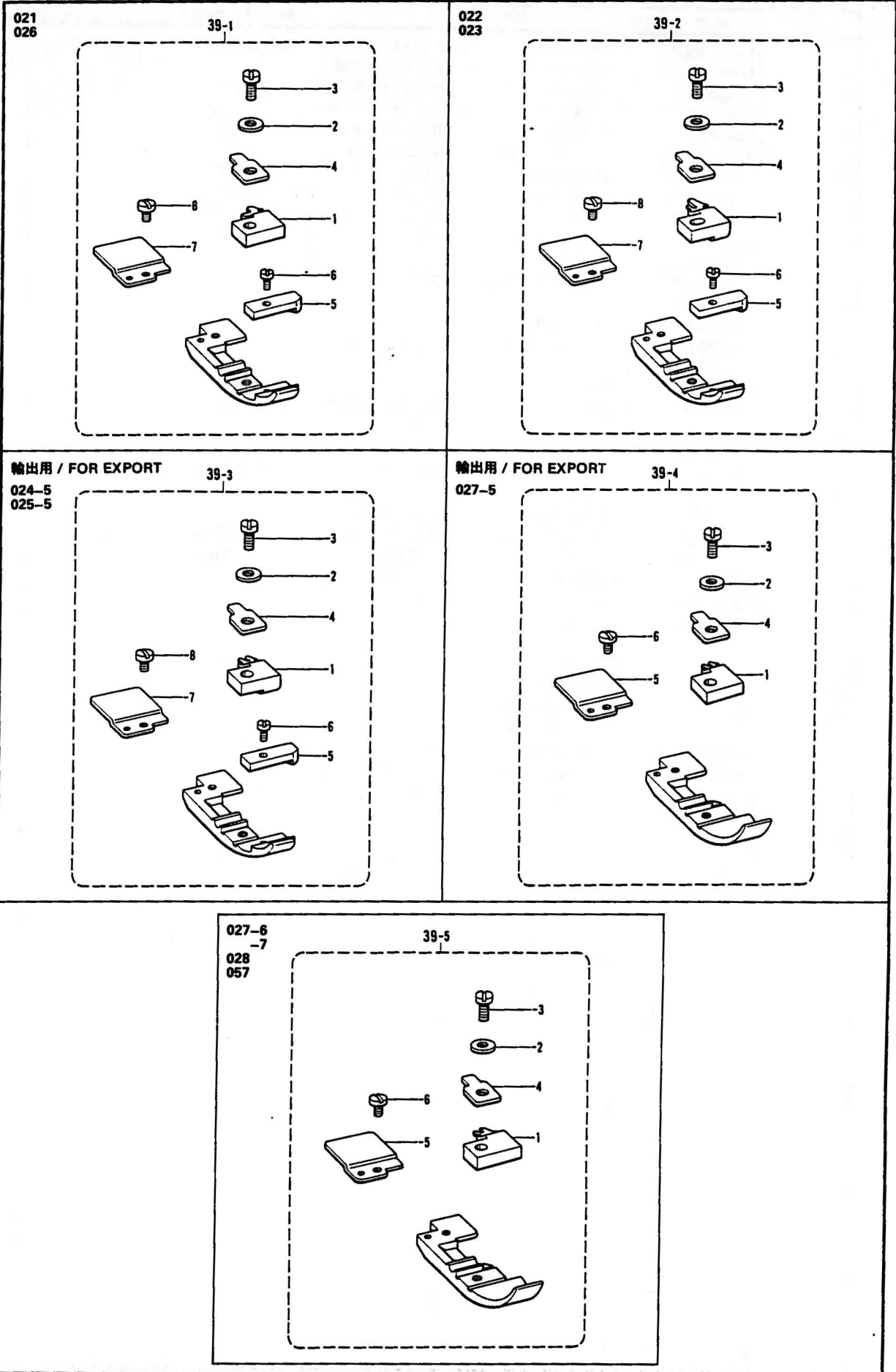



E. 押工関係/Presser foot mechanism/Stoffdrückerfuß/  
 Mécanisme du pied presseur/Mecanismo del prensa telas

REF.NO.	CODE	QTY	ヒンメイ	NAME OF PARTS	RMKS
39-1	154986101	1	オサイクミ <021>	PRESSER FOOT ASSEMBLY <021.026>	
39-1-1	146964001	1	ツメ	STITCH TONGUE	
39-1-2	025030132	1	ヒラサ"カ"ネシヨウ3	WASHER 3	
39-1-3	100080004	1	シメネシ"3.18	SCREW 3.18	
39-1-4	146887001	1	オサイササエ	PRESSER FOOT HINGE SPRING	
39-1-5	146888002	1	オサイF	PRESSER FOOT (FRONT)	
39-1-6	S01295001	1	シメネシ"2.38X3.5	SCREW 2.38X3.5	
39-1-7	154969002	1	オサイB	PRESSER FOOT (REAR)	
39-1-8	105288001	1	シメネシ"2.38	SCREW 2.38	
39-2	156565001	1	オサイクミ <022.023>	PRESSER FOOT ASSEMBLY <022.023>	
39-2-1	149525001	1	ツメ	STITCH TONGUE	
39-2-2	025030132	1	ヒラサ"カ"ネシヨウ3	WASHER 3	
39-2-3	100080004	1	シメネシ"3.18	SCREW 3.18	
39-2-4	146887001	1	オサイササエ	PRESSER FOOT HINGE SPRING	
39-2-5	146888002	1	オサイF	PRESSER FOOT (FRONT)	
39-2-6	S01295001	1	シメネシ"2.38X3.5	SCREW 2.38X3.5	
39-2-7	154969002	1	オサイB	PRESSER FOOT (REAR)	
39-2-8	105288001	1	シメネシ"2.38	SCREW 2.38	
39-3	159967101	1	-----	PRESSER FOOT ASSEMBLY <024.025/-5>	
39-3-1	159968001	1	-----	STITCH TONGUE	
39-3-2	025030132	1	-----	WASHER 3	
39-3-3	100080004	1	-----	SCREW 3.18	
39-3-4	146887001	1	-----	PRESSER FOOT HINGE SPRING	
39-3-5	146888002	1	-----	PRESSER FOOT (FRONT)	
39-3-6	S01295001	1	-----	SCREW 2.38X3.5	
39-3-7	154969002	1	-----	PRESSER FOOT (REAR)	
39-3-8	105288001	1	-----	SCREW 2.38	
39-4	154989001	1	-----	PRESSER FOOT ASSEMBLY <027-5>	
39-4-1	146907001	1	-----	STITCH TONGUE	
39-4-2	025030132	1	-----	WASHER 3	
39-4-3	100080004	1	-----	SCREW 3.18	
39-4-4	146887001	1	-----	PRESSER FOOT HINGE SPRING	
39-4-5	154969002	1	-----	PRESSER FOOT (REAR)	
39-4-6	105288001	1	-----	SCREW 2.38	
39-5	154985001	1	オサイクミ<027-6>	PRESSER FOOT ASSEMBLY <027-6,-7. 028.057>	
39-5-1	146905001	1	ツメ	STITCH TONGUE	
39-5-2	025030132	1	ヒラサ"カ"ネシヨウ3	WASHER 3	
39-5-3	100080004	1	シメネシ"3.18	SCREW 3.18	
39-5-4	146887001	1	オサイササエ	PRESSER FOOT HINGE SPRING	
39-5-5	154969002	1	オサイB	PRESSER FOOT (REAR)	
39-5-6	105288001	1	シメネシ"2.38	SCREW 2.38	

E. 押工関係/Presser foot mechanism/Stoffdrückerfuß/  
 Mécanisme du pied presseur/Mecanismo del prensa telas

024-6  
 025-6  
 -7  
 031  
 032

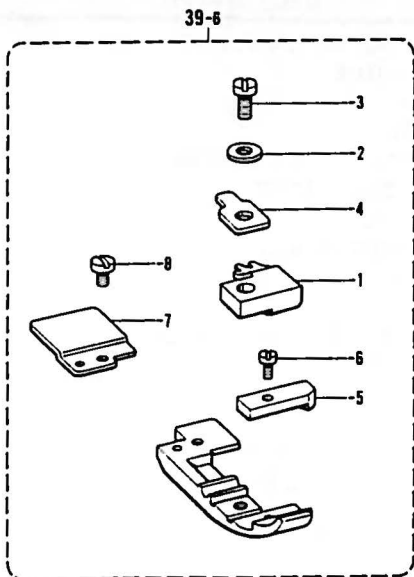

033  
 034

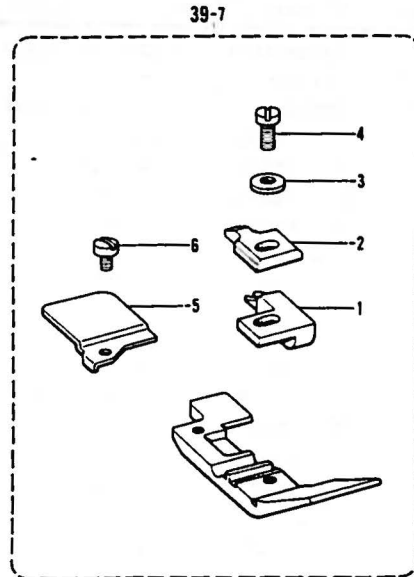

037

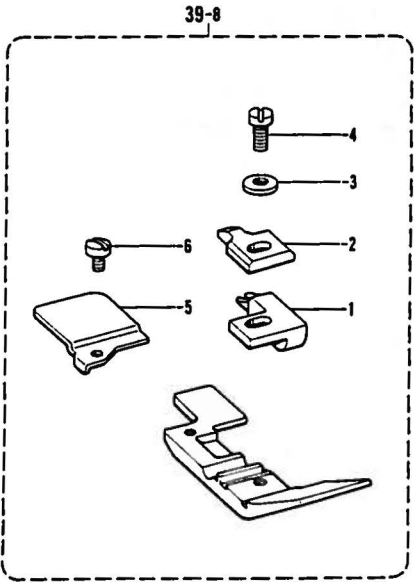

国内用 / FOR DOMESTIC

041

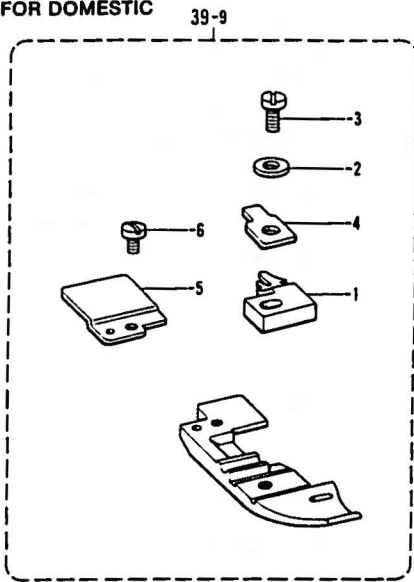

045  
 046

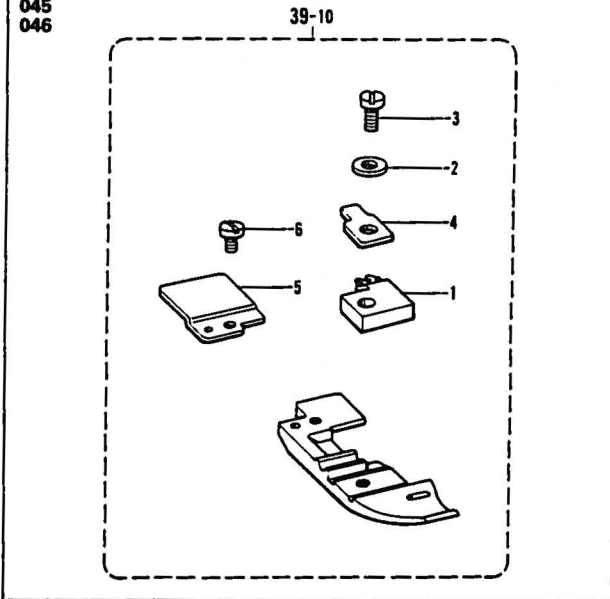



E. 押工関係/Presser foot mechanism/Stoffdrückerfuß/  
 Mécanisme du pied presseur/Mecanismo del prensa telas

REF NO.	CODE	Q'TY	品名	NAME OF PARTS	RMKS
39-6	154987201	1	オサイクミ <031>	PRESSER FOOT ASSEMBLY <024-6.025-6,-7.031.032>	
39-6-1	146966002	1	ツメ	STITCH TONGUE	
39-6-2	025030132	1	ヒラサ"カ"ネシヨウ3	WASHER 3	
39-6-3	100080004	1	シメネシ"3.18	SCREW 3.18	
39-6-4	146887001	1	オサイササエ	PRESSER FOOT HINGE SPRING	
39-6-5	146888002	1	オサイF	PRESSER FOOT (FRONT)	
39-6-6	S01295001	1	シメネシ"2.38X3.5	SCREW 2.38X3.5	
39-6-7	154969002	1	オサイB	PRESSER FOOT (REAR)	
39-6-8	105288001	1	シメネシ"2.38	SCREW 2.38	
39-7	S07201001	1	オサイクミ <033>	PRESSER FOOT ASSEMBLY <033.034>	
39-7-1	144816001	1	ツメV	STITCH TONGUE (V)	
39-7-2	144091001	1	オサイササエ	PRESSER FOOT PLATE	
39-7-3	025030132	1	ヒラサ"カ"ネシヨウ3	WASHER 3	
39-7-4	100080004	1	シメネシ"3.18	SCREW 3.18	
39-7-5	154972001	1	オサイB	PRESSER FOOT (REAR)	
39-7-6	105288001	1	シメネシ"2.38	SCREW 2.38	
39-8	S07202001	1	オサイクミ <037>	PRESSER FOOT ASSEMBLY <037>	
39-8-1	144816001	1	ツメV	STITCH TONGUE (V)	
39-8-2	144091001	1	オサイササエ	PRESSER FOOT PLATE	
39-8-3	025030132	1	ヒラサ"カ"ネシヨウ3	WASHER 3	
39-8-4	100080004	1	シメネシ"3.18	SCREW 3.18	
39-8-5	154972001	1	オサイB	PRESSER FOOT (REAR)	
39-8-6	105288001	1	シメネシ"2.38	SCREW 2.38	
39-9	156566101	1	オサイクミ <041>	-----	
39-9-1	149526101	1	ツメ	-----	
39-9-2	025030132	1	ヒラサ"カ"ネシヨウ3	-----	
39-9-3	100080004	1	シメネシ"3.18	-----	
39-9-4	146887001	1	オサイササエ	-----	
39-9-5	154969002	1	オサイB	-----	
39-9-6	105288001	1	シメネシ"2.38	-----	
39-10	156564001	1	オサイクミ <045>	PRESSER FOOT ASSEMBLY <045.046>	
39-10-1	146907001	1	ツメ	STITCH TONGUE	
39-10-2	025030132	1	ヒラサ"カ"ネシヨウ3	WASHER 3	
39-10-3	100080004	1	シメネシ"3.18	SCREW 3.18	
39-10-4	146887001	1	オサイササエ	PRESSER FOOT HINGE SPRING	
39-10-5	154969002	1	オサイB	PRESSER FOOT (REAR)	
39-10-6	105288001	1	シメネシ"2.38	SCREW 2.38	

E. 押工関係/Presser foot mechanism/Stoffdrückerfuß/  
 Mécanisme du pied presseur/Mecanismo del prensa telas

049

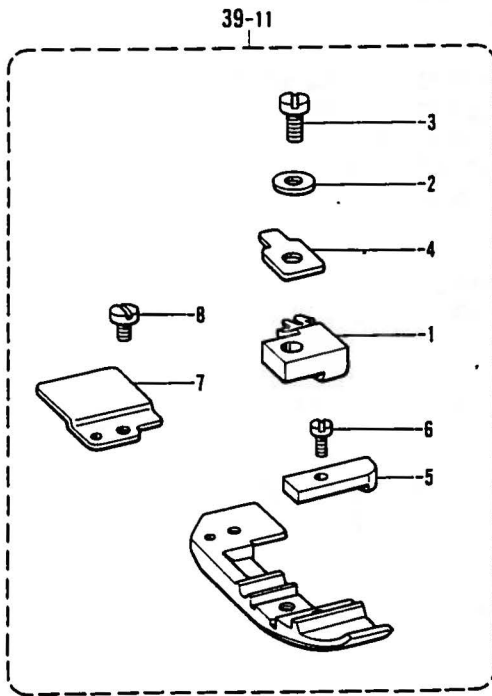

国内用 / FOR DOMESTIC

050

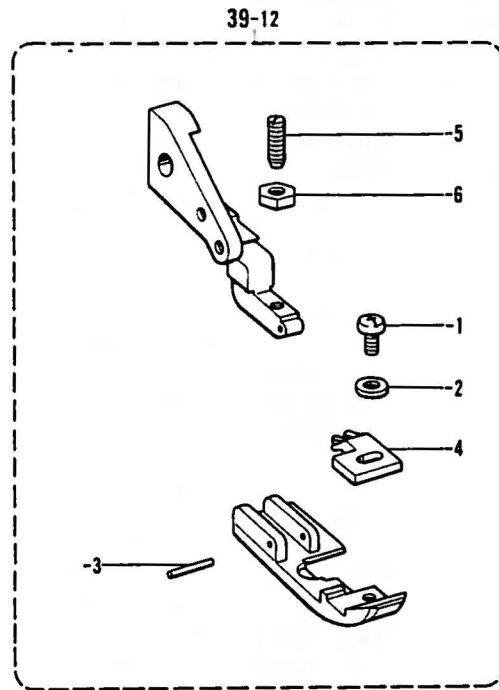

輸出用 / FOR EXPORT

051

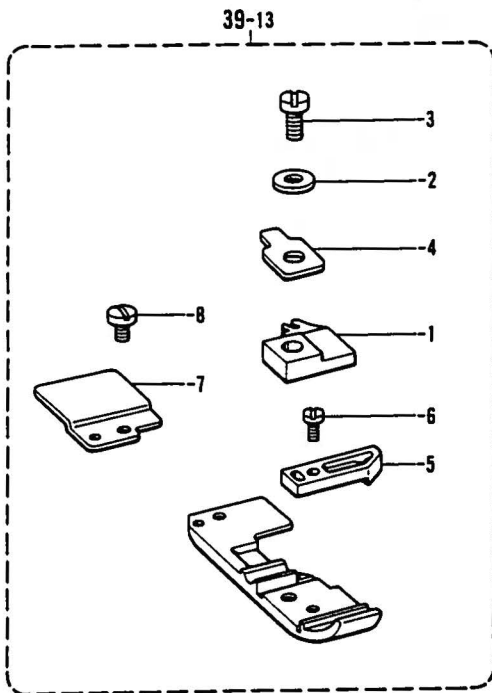

輸出用 / FOR EXPORT

056

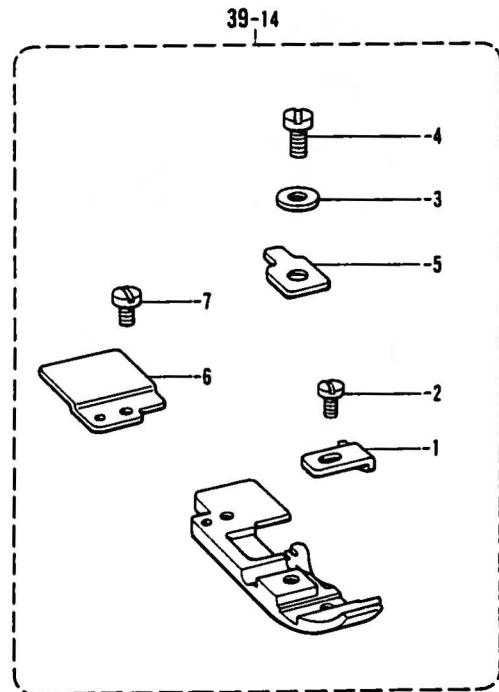

E. 押工関係/Presser foot mechanism/Stoffdrückerfuß/  
 Mécanisme du pied presseur/Mecanismo del prensa telas

REF NO	CODE	Q'TY	品名	NAME OF PARTS	RMKS
39-11	S11117101	1	オサイクミ <049>	PRESSER FOOT ASSEMBLY <049>	
39-11-1	146903002	1	ツメ	STITCH TONGUE	
39-11-2	025030132	1	ヒラサ"カ"ネシヨウ3	WASHER 3	
39-11-3	100080004	1	シメネシ"3.18	SCREW 3.18	
39-11-4	146887001	1	オサイササエ	PRESSER FOOT HINGE SPRING	
39-11-5	146888002	1	オサイF	PRESSER FOOT (FRONT)	
39-11-6	S01295001	1	シメネシ"2.38X3.5	SCREW 2.38X3.5	
39-11-7	154969002	1	オサイB	PRESSER FOOT (REAR)	
39-11-8	105288001	1	シメネシ"2.38	SCREW 2.38	
39-12	149195101	1	オサイクミ <050>	-----	
39-12-1	062660412	1	ナヘ"ユ318~40X4	-----	
39-12-2	025030132	1	ヒラサ"カ"ネシヨウ3	-----	
39-12-3	149183001	1	オサイヒ"ン	-----	
39-12-4	150739001	1	ツメ	-----	
39-12-5	103978002	1	トメネシ"3.18	-----	
39-12-6	021660102	1	ナツト1シユ3.18	-----	
39-13	154998001	1	-----	PRESSER FOOT ASSEMBLY <051>	
39-13-1	150871001	1	-----	STITCH TONGUE	
39-13-2	025030132	1	-----	WASHER 3	
39-13-3	100080004	1	-----	SCREW 3.18	
39-13-4	146887001	1	-----	PRESSER FOOT HINGE SPRING	
39-13-5	150872001	1	-----	PRESSER FOOT (FRONT)	
39-13-6	S01295001	1	-----	SCREW 2.38X3.5	
39-13-7	154969002	1	-----	PRESSER FOOT (REAR)	
39-13-8	140530002	1	-----	SCREW 2.38	
39-14	156189001	1	-----	PRESSER FOOT ASSEMBLY <056>	
39-14-1	147371001	1	-----	PRESSER FOOT (FRONT)	
39-14-2	105288001	1	-----	SCREW 2.38	
39-14-3	025030132	1	-----	WASHER 3	
39-14-4	100080004	1	-----	SCREW 3.18	
39-14-5	146887001	1	-----	PRESSER FOOT HINGE SPRING	
39-14-6	154969002	1	-----	PRESSER FOOT (REAR)	
39-14-7	105288001	1	-----	SCREW 2.38	



F. 送り関係/Feed mechanism/Transportvorrichtung/  
Mécanisme de l'entraînement/Mecanismo de la alimentación

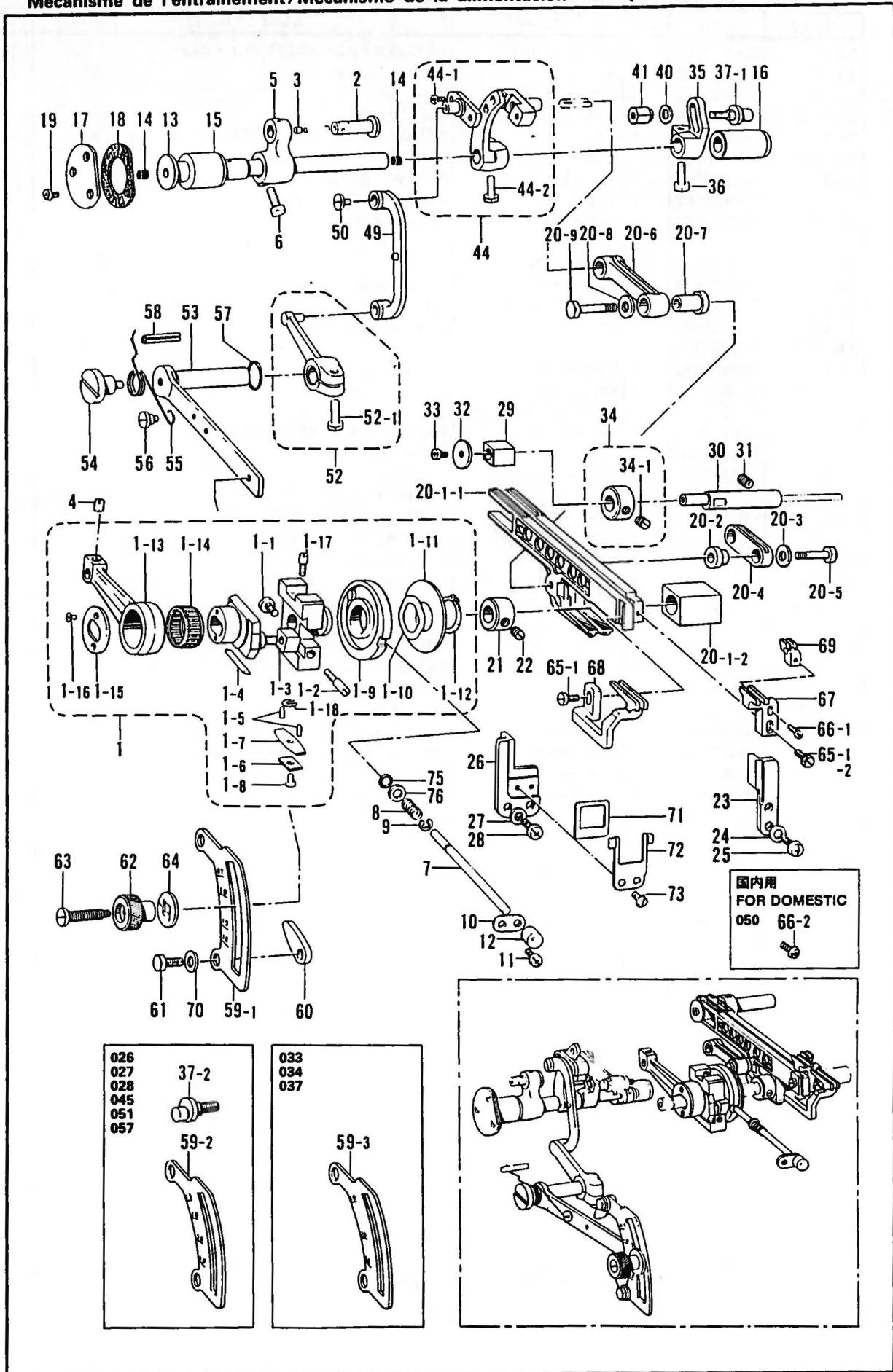

F. 送り関係/Feed mechanism/Transportvorrichtung/  
Mécánisme de l'entraînement/Mecanismo de la alimentación

REF NO	CODE	Q'TY	ヒンメイ	NAME OF PARTS	RMKS
1	146528101	1	ヘンシンリンクミ	ECCENTRIC WHEEL ASSEMBLY	
1-1	S16498001	1	シメネシ"4.37	SCREW 4.37	
1-2	145663001	1	トメネシ"4.37	SCREW 4.37	
1-3	140165001	1	チヨウセツヒンカクコマ	SLIDE BLOCK	
1-4	146401001	1	シ"フ"	GIB	
1-5	146402002	2	シ"フ"オサエヒン	GIB HOLDER PIN	
1-6	146403001	1	シ"フ"オサエイタハ"ネS	GIB HOLDER PLATE (S)	
1-7	146404001	1	シ"フ"オサエイタハ"ネL	GIB HOLDER PLATE (L)	
1-8	062660512	1	ナヘ"コネシ"318-40X5	SCREW 318X5	
1-9	144053001	1	ヘンシンチヨウセツカムクミ	ECCENTRIC WHEEL ADJUSTING CAM	
1-10	144055001	1	ナミハ"ネ	WAVE SPRING	
1-11	146529001	1	サ"ガ"ネ	WASHER	
1-12	048150143	1	トメワシ"クヨウC15	STOP RING C15	
1-13	146530001	1	オクリロツト"	FEED ROD	
1-14	146531001	1	ニ-ト"ルシ"クウケ20	NEEDLE ROLLER BEARING 20	
1-15	140176001	1	オクリロツト"オサエイタ	FEED ROD PRESSER PLATE	
1-16	117517003	2	サラネシ"2.38	SCREW 2.38	
1-17	100025002	2	シメネシ"4.76	SCREW 4.76	
2	146532001	1	オクリロツト"ヒン	FEED ARM PIN	
3	140326009	1	ゴ"ムセ	OIL CAP	
4	100251001	1	トメネシ"6.35	SCREW 6.35	
5	146533001	1	オクリウテ"	FEED ARM	
6	017771612	1	ホ"ルト6.35X16	BOLT 6.35X16	
7	146534001	1	オクリチヨウセツホ"タンシ"ク	FEED ADJUSTING SHAFT	
8	S11072001	1	ホ"タンシ"クハ"ネ	SPRING	
9	048040342	1	トメワE4	STOP RING E4	
10	146536001	1	オクリホ"タンシ"クササエ	SUPPORTER FOR FEED ADJUSTING SHAFT	
11	062670612	1	ナヘ"コ357-40X6	SCREW 357X6	
12	146537000	1	キヤツフ"	CAP	
13	146538001	1	オクリシ"ク	FEED SHAFT	
14	140327001	2	ゴ"ムセ	OIL CAP	
15	146539000	1	オクリシ"クメタルL	FEED SHAFT BUSHING (LEFT)	
16	146540000	1	オクリシ"クメタルR	FEED SHAFT BUSHING (RIGHT)	
17	140188004	1	オクリシ"クメタルLフタ	COVER FOR FEED SHAFT BUSHING (LEFT)	
18	140187000	1	ハ"ツキン	PACKING	
19	062670812	3	ナヘ"コ357-40X8	SCREW 357X8	
20	159475001	1	オクリタ"イカクコマリンククミ	FEED BAR GUIDE BLOCK LINK ASSEMBLY	
20-1	146541001	1	オクリタ"イカクコマクミ	FEED BAR GUIDE BLOCK ASSEMBLY	
20-1-1	147773001	1	オクリタ"イクミ	FEED BAR ASSEMBLY	
20-1-2	146544000	1	シ"ヨウケ"オクリカクコマ	FEED LIFTING SLIDE BLOCK	
20-2	140207001	1	シユオクリリンクフ"シユ	MAIN FEED LINK BUSHING	
20-3	140208001	1	サ"ガ"ネ	WASHER	
20-4	140209001	1	シユオクリリンク	MAIN FEED LINK	
20-5	140210001	1	シユオクリリンクシ"クS	MAIN FEED LINK SHAFT (SMALL)	
20-6	146554001	1	サト"ウオクリリンク	DIFFERENTIAL FEED LINK	
20-7	146555001	1	サト"ウオクリリンクフ"シユ	DIFFERENTIAL FEED LINK BUSHING	
20-8	140208001	1	サ"ガ"ネ	WASHER	
20-9	140217001	1	オクリリンクシ"クL	FEED LINK SHAFT (LARGE)	
21	146741000	1	セツトカラ-	SET COLLAR	
22	101706001	1	トメネシ"6.35	SCREW 6.35	
23	148174000	1	オクリタ"イアンナイR	FEED BAR GUIDE (RIGHT)	
24	100645003	2	サ"ガ"ネ	WASHER	
25	062681012	2	ナヘ"コ437-40X10	SCREW 437X10	
26	149888000	1	オクリタ"イアンナイL	FEED BAR GUIDE (LEFT)	
27	100645003	2	サ"ガ"ネ	WASHER	
28	062681012	2	ナヘ"コ437-40X10	SCREW 437X10	
29	146547000	1	オクリタ"イカクコマ	FEED BAR SLIDE BLOCK	
30	146548101	1	オクリタ"イカクコマシ"ク	FEED BAR GUIDE BLOCK SHAFT	
31	014770622	1	アトメネシ"6.35クホ"ミ	SCREW 6.35	
32	146549001	1	オクリタ"イカクコマアテイタ	SLIDE PLATE	
33	062680712	1	ナヘ"コ437-40X7	SCREW 437X7	



F. 送り関係/Feed mechanism/Transportvorrichtung/  
 Mécanisme de l'entraînement/Mecanismo de la alimentación

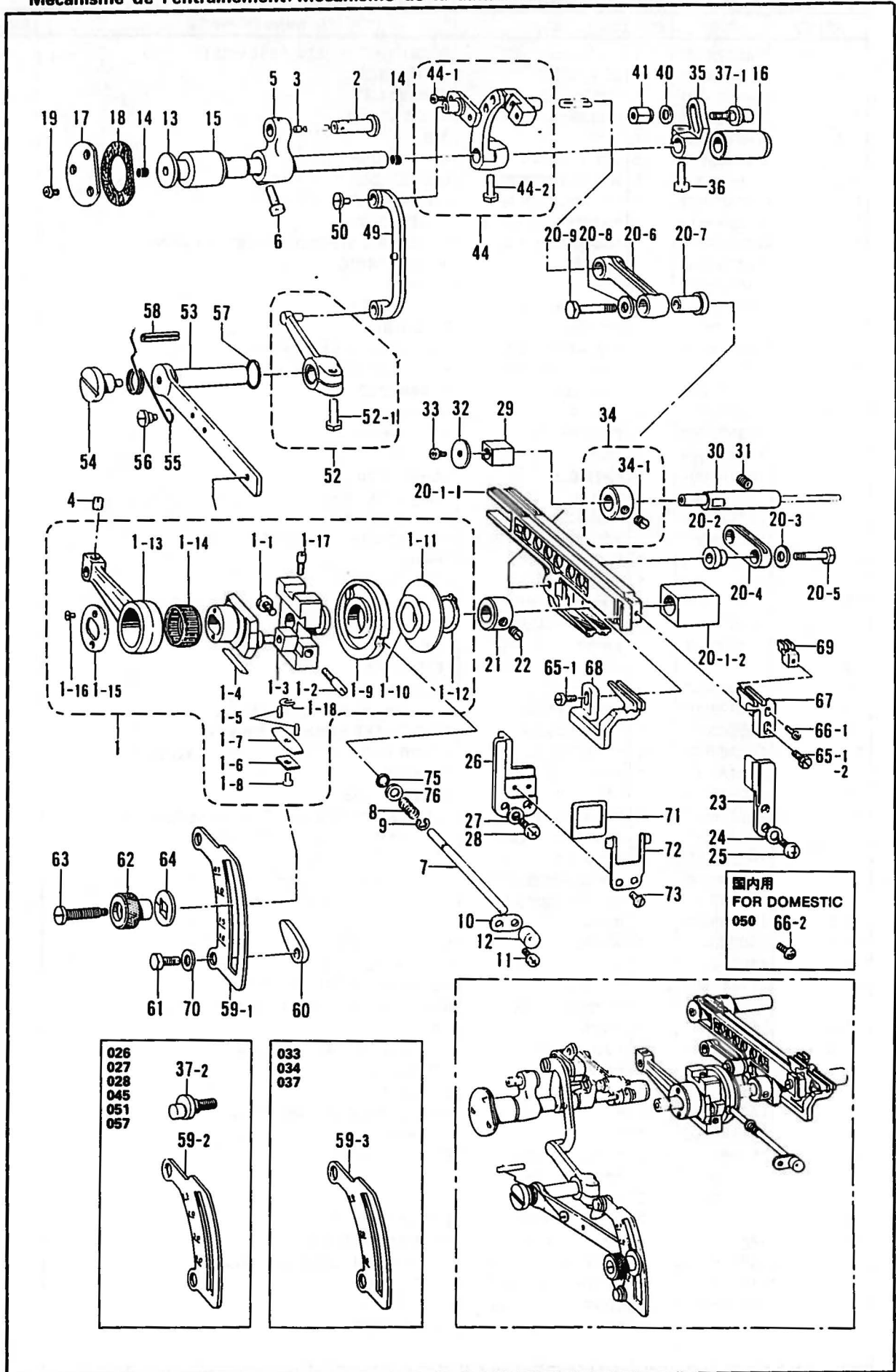



F. 送り関係/Feed mechanism/Transportvorrichtung/  
Mécánisme de l'entraînement/Mecanismo de la alimentación

REF NO.	CODE	QTY	ヒンメイ	NAME OF PARTS	RMKS
34	181969003	1	セツトカラークミ	SET COLLAR ASSEMBLY	
34-1	101706001	2	トメネシ"6.35	SCREW 6.35	
35	140205001	1	シユオクリウテ"	MAIN FEED ARM	
36	017771412	1	ボ"ルト6.35X14	BOLT 6.35X14	
37-1	143564001	1	シユオクリシ"ク	MAIN FEED SHAFT	
37-2	144068001	1	シユオクリシ"ク	MAIN FEED SHAFT	
40	140208001	1	サ"カ"ネ	WASHER	
41	143565001	1	ナツト4.76	NUT 4.76	
44	146550001	1	サト"ウオクリウテ"クミ	DIFFERENTIAL FEED ARM ASSEMBLY	
44-1	062660712	2	ナヘ"コ318-40X7	SCREW 318X7	
44-2	017771412	1	ボ"ルト6.35X14	BOLT 6.35X14	
49	146556001	1	サト"ウリウテ"ク	DIFFERENTIAL FEED ADJUSTING LINK	
50	148834001	1	シメネシ"3.57	SCREW 3.57	
52	146914001	1	リンクレハ"ーネシ"ツキ	LINK LEVER WITH SCREW	
52-1	017771412	1	ボ"ルト6.35X14	BOLT 6.35X14	
53	146558001	1	サト"ウチヨウセツレハ"ー	DIFFERENTIAL FEED ADJUSTING LEVER	
54	146559001	1	タ"ンネシ"5.56	STUD SCREW 5.56	
55	*	1	レハ"ーハ"ネ	LEVER SPRING	
56	100294002	1	タ"ンネシ"4.76	STUD SCREW 4.76	
57	109203001	1	Oリング"	O RING	
58	047502242	1	スプリング"ヒ"ンAW5	SPRING PIN AW5	
59-1	146561001	1	サト"ウリヨウメモリイタ <シ"ヌイヨウ>	DIFFERENTIAL STITCH CONTROL PLATE <PLAIN STITCHING>	
59-2	146742001	1	サト"ウリヨウメモリイタ <ハ"ルキ"ヨウ>	DIFFERENTIAL STITCH CONTROL PLATE <BULKY>	
59-3	146562001	1	サト"ウリヨウメモリイタ <ラフラー"ヨウ>	DIFFERENTIAL STITCH CONTROL PLATE <RUFFLING>	
60	146563001	2	チヨウセツレハ"ーストツハ"	STOPPER FOR DIFFERENTIAL STITCH CONTROL	
61	017771612	2	ボ"ルト6.35X16	BOLT 6.35X16	
62	146564001	1	セツトネシ"ツマミ	KNOB	
63	146565001	1	セツトネシ"	SET SCREW	
64	146566001	1	サ"カ"ネ	WASHER	
65-1	117516001	2	ボ"ルト4.37	BOLT 4.37	
65-2	117516001	1	ボ"ルト4.37 <ハ"イヒ"ンク"ヨウ>	----- -----	
66-1	062630812	1	ナヘ"コ238-56X8	SCREW 238X8	
66-2	062660712	1	ナヘ"コ318-40X7 <ハ"イヒ"ンク"ヨウ>	----- -----	
67	*	1	シユオクリハ"	MAIN FEED DOG	
68	*	1	サト"ウオクリハ"	DIFFERENTIAL FEED DOG	
69	*	1	ホシ"ヨオクリハ"	CHAIN FEED DOG	
70	025770232	2	ヒラサ"カ"ネチユウ6.35	WASHER 6.35	
71	149886000	1	ホ"ウシ"ンイタ	FRAGMENT PROTECTOR	
72	149887001	1	ホ"ウシ"ンイタササエ	FRAGMENT PROTECTOR PLATE	
73	S01297001	2	シメネシ"3.57X3.5	SCREW 3.57X3.5	
75	118770001	1	ハ"ツキン	PACKING	
76	113431002	1	サ"カ"ネ	WASHER	

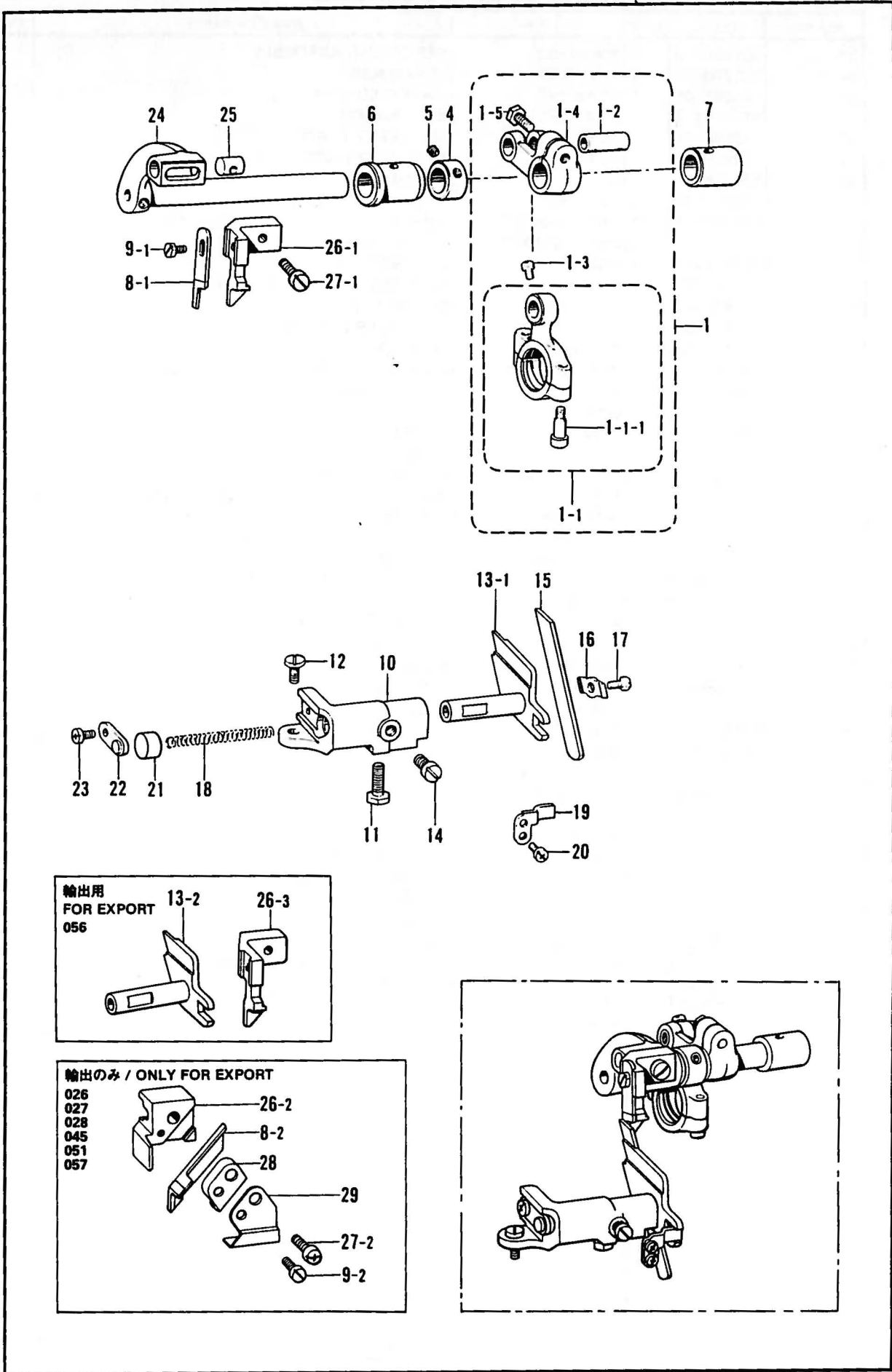

G. 上メス・下メス関係/Knife mechanism/Messer/Mécanisme du couteau/Mecanismo del cuchilla

REF NO	CODE	Q'TY	品名	NAME OF PARTS	RMKS
1	148427001	1	ウフメスクランクロッド"ウミ	UPPER KNIFE DRIVING ROD ASSEMBLY	
1-1	S01223001	1	ウフメスロッド"ネジ"ツキ	UPPER KNIFE ROD WITH SCREW	
1-1-1	148425001	2	アナボルト4.37X14	BOLT 4.37X14	
1-2	140232001	1	ウフメスクランクロッド"ピン	CRANK ROD PIN	
1-3	100366001	1	マルヒラトメネジ"4.37	SCREW 4.37	
1-4	140233001	1	ウフメスクランクシ"クウテ"	UPPER KNIFE DRIVING LEVER	
1-5	017771612	1	ボルト6.35X16	BOLT 6.35X16	
4	146581001	1	セットカラー	SET COLLAR	
5	100260001	2	トメネジ"5.95	SCREW 5.95	
6	140235000	1	ウフメスサト"ウウテ"メタルL	UPPER KNIFE DRIVING ARM BUSHING (LEFT)	
7	144117000	1	ウフメスサト"ウウテ"メタルR	UPPER KNIFE DRIVING ARM BUSHING (RIGHT)	
8-1	144074100	1	ウフメス	UPPER KNIFE	
8-2	148815001	1	-----	ANGLE KNIFE WITH CARBIDE TIP	
9-1	144075001	1	ボルト3.57	BOLT 3.57	
9-2	113050001	1	-----	SCREW 3.57	
10	146582001	1	シタメストリツケタ"イササエ	LOWER KNIFE HOLDER SUPPORTER	
11	017771412	1	ボルト6.35X14	BOLT 6.35X14	
12	107407003	1	シメネジ"4.37	SCREW 4.37	
13-1	146754001	1	シタメストリツケタ"イ	LOWER KNIFE HOLDER	
13-2	146583001	1	-----	LOWER KNIFE HOLDER <BINDING>	
14	102627001	1	アタマツキトメネジ"6.35	SCREW 6.35	
15	112436001	1	シタメス	LOWER KNIFE	
16	117515001	1	シタメスオサエ	LOWER KNIFE PRESSER PLATE	
17	117516001	1	ボルト4.37	BOLT 4.37	
18	146584001	1	シタメストリツケタ"イハ"ネ	LOWER KNIFE HOLDER SPRING	
19	146585001	1	シタメストリツケタ"イアンナイ	LOWER KNIFE HOLDER GUIDE	
20	062670612	2	ナヘ"J357-40X6	SCREW 357X6	
21	146586009	1	メクラセン	OIL CAP	
22	140248001	1	トリツケタ"イハ"ネオサエ	LOWER KNIFE HOLDER SPRING STOPPER	
23	062680712	1	ナヘ"J437-40X7	SCREW 437X7	
24	146580001	1	ウフメスサト"ウウテ"	UPPER KNIFE DRIVING ARM	
25	148281101	1	ウフメスタ"キナツト	NUT	
26-1	144073001	1	ウフメスタ"キ	UPPER KNIFE HOLDER	
26-2	148341001	1	-----	UPPER KNIFE HOLDER <BULKY>	
26-3	144179001	1	-----	UPPER KNIFE HOLDER <BINDING>	
27-1	107407003	1	シメネジ"4.37	SCREW 4.37	
27-2	062681612	1	-----	SCREW 437X16	
28	148343101	1	-----	UPPER KNIFE PRESSER	
29	148344001	1	-----	UPPER KNIFE PRESSER PLATE	



H. ラフラー装置関係/Ruffling attachment/Kräuselvorrichtung/  
 Accessoire pour fronces/Accessorio de fruncido

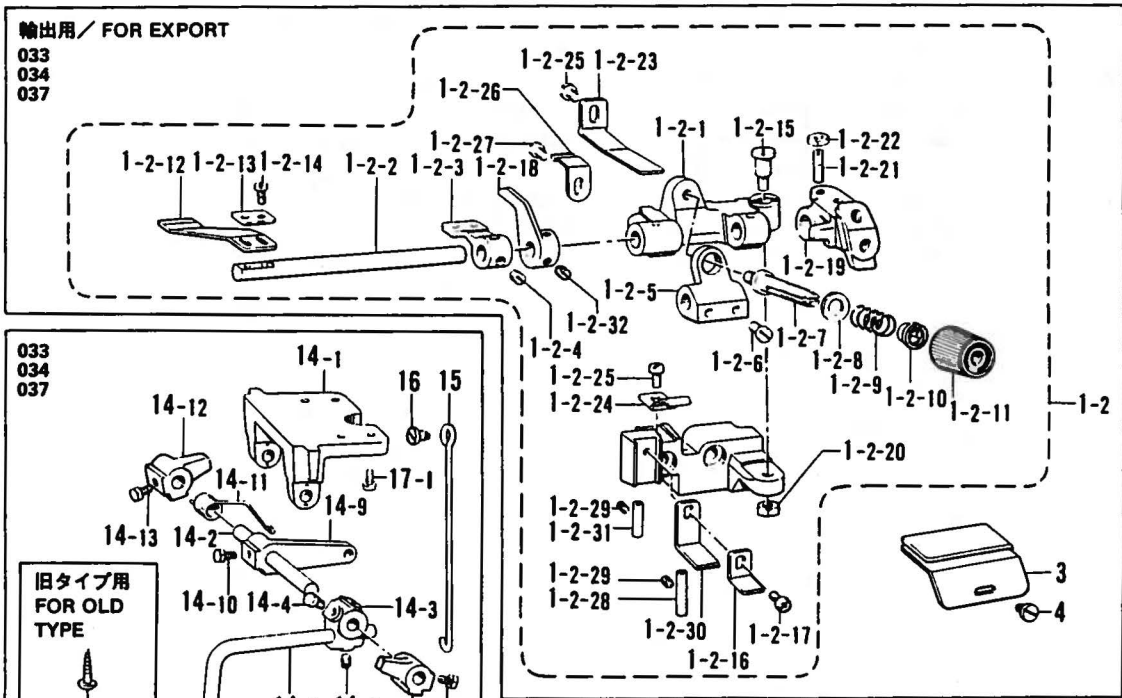
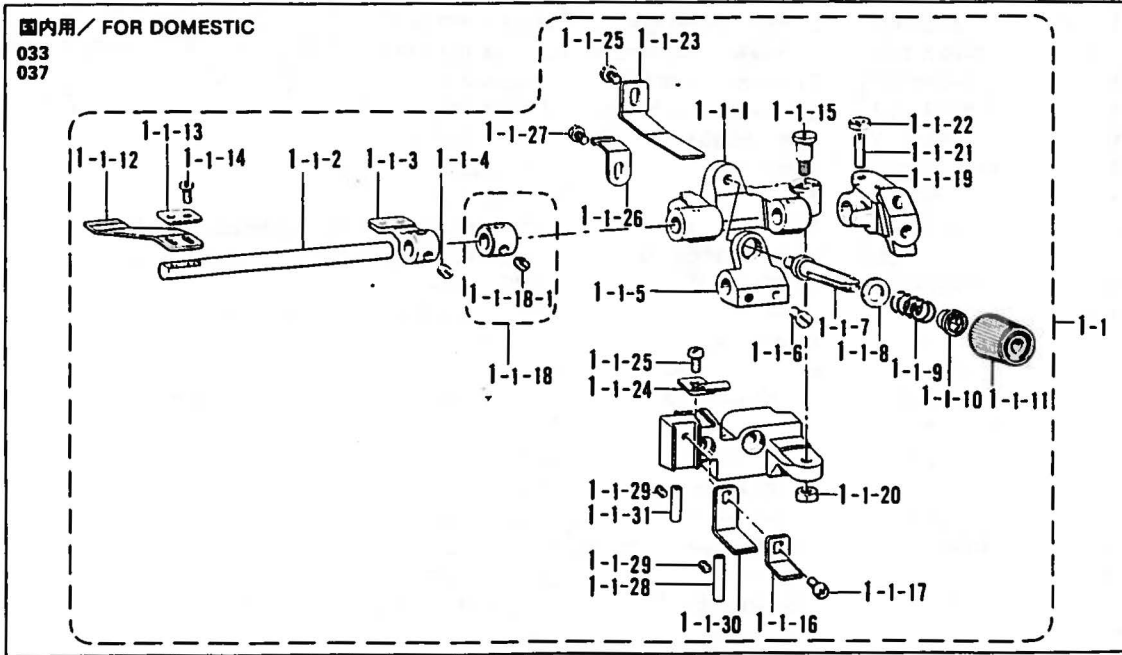

H. ラフラー装置関係/Ruffling attachment/Kräuselvorrichtung/  
Accessoire pour fronces/Accessorio de fruncido

REF NO.	CODE	QTY	ヒンメイ	NAME OF PARTS	RMKS
1-1	146587209	1	ラフラーソウチクミ	-----	
1-1-1	146588001	1	キシ"オサエタイ	-----	
1-1-2	145803001	1	キシ"オサエトリツケジク	-----	
1-1-3	146589001	1	ラツハト"ダイ	-----	
1-1-4	101706001	2	トメネジ"6.35	-----	
1-1-5	146590001	1	ハ"ネウケ	-----	
1-1-6	105163001	2	アタマツキトメネジ"5.95	-----	
1-1-7	110820101	1	イトチヨウシホ"ウ	-----	
1-1-8	025770232	1	ヒラサ"カ"ネチユウ6.35	-----	
1-1-9	144788001	1	キシ"オサエハ"ネ	-----	
1-1-10	144105000	1	チヨウシハ"ネウエサ"カ"ネ	-----	
1-1-11	149566009	1	イトチヨウシナツト	-----	
1-1-12	144783001	1	キシ"オサエ	-----	
1-1-13	144784001	1	キシ"オサエサ"カ"ネ	-----	
1-1-14	062660712	2	ナヘ"コ318-40X7	-----	
1-1-15	147933001	1	タ"ンネジ"5.95	-----	
1-1-16	145807001	1	キシ"オサエタイアンナイ	-----	
1-1-17	062680812	1	ナヘ"コ437-40X8	-----	
1-1-18	181995002	1	セツトカラークミ	-----	
1-1-18-1	101706001	2	トメネジ"6.35	-----	
1-1-19	145810001	1	ハント"ルトリツケイタ	-----	
1-1-20	150553002	1	ナツト5.95	-----	
1-1-21	110230001	1	トメネジ"4.37	-----	
1-1-22	105234003	1	ナツト4.37	-----	
1-1-23	145811001	1	ハント"ルモト"シイタハ"ネ	-----	
1-1-24	145808001	1	キシ"オサエタイトメハ"ネ	-----	
1-1-25	062680612	2	ナヘ"コ4.37-40X6	-----	
1-1-26	144764001	1	マエフタトメイタハ"ネ	-----	
1-1-27	060670512	1	ハ"イント"357-40X5	-----	
1-1-28	146592001	1	イトアンナイハ"イフ	-----	
1-1-29	013679412	2	トメネジ"3.57クホ"ミ	-----	
1-1-30	154795001	1	キシ"オサエタイアンナイD	-----	
1-1-31	S01614001	1	イトアンナイハ"イフ	-----	
1-2	S12677009	1	-----	RUFFLER ATTACHMENT ASSEMBLY	
1-2-1	146588001	1	-----	BRACKET FOR RUFFLING BLADE	
1-2-2	145803001	1	-----	RUFFLING BLADE BASE SHAFT	
1-2-3	146589001	1	-----	LAPPER BASE	
1-2-4	101706001	2	-----	SCREW 6.35	
1-2-5	146590001	1	-----	SPRING BASE	
1-2-6	105163001	2	-----	SCREW 5.95	
1-2-7	110820101	1	-----	TENSION CONTROL STUD	
1-2-8	025770232	1	-----	WASHER 6.35	
1-2-9	144788001	1	-----	SPRING	
1-2-10	144105000	1	-----	TENSION SPRING WASHER	
1-2-11	149566009	1	-----	THREAD TENSION ADJUSTING NUT	
1-2-12	144783001	1	-----	RUFFLING BLADE	
1-2-13	144784001	1	-----	WASHER	
1-2-14	062660712	2	-----	SCREW 318X7	
1-2-15	147933001	1	-----	STUD SCREW 5.95	
1-2-16	145807001	1	-----	RUFFLING BLADE GUIDE	
1-2-17	062680812	1	-----	SCREW 437X8	
1-2-18	148387001	1	-----	RUFFLING PLATE LIFTER	
1-2-19	145810001	1	-----	HANDLE FIXING PLATE	
1-2-20	150553002	1	-----	NUT 5.95	
1-2-21	110230001	1	-----	SCREW 4.37	
1-2-22	105234003	1	-----	NUT 4.37	
1-2-23	145811001	1	-----	SPRING PLATE	
1-2-24	145808001	1	-----	SPRING PLATE	
1-2-25	062680612	2	-----	SCREW 437X6	
1-2-26	144764001	1	-----	FRONT COVER STOPPER SPRING	
1-2-27	060670512	1	-----	SCREW 357X5	
1-2-28	146592001	1	-----	THREAD GUIDE PIPE	

H. ラフラー装置関係 / Ruffling attachment / Kräuselvorrichtung /  
 Accessoire pour fronces / Accesorio de fruncido

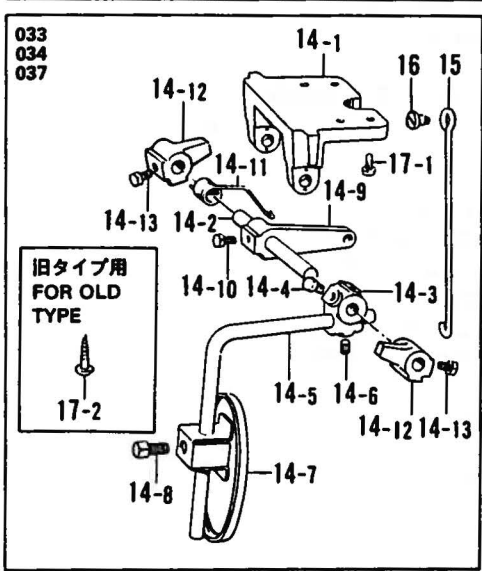
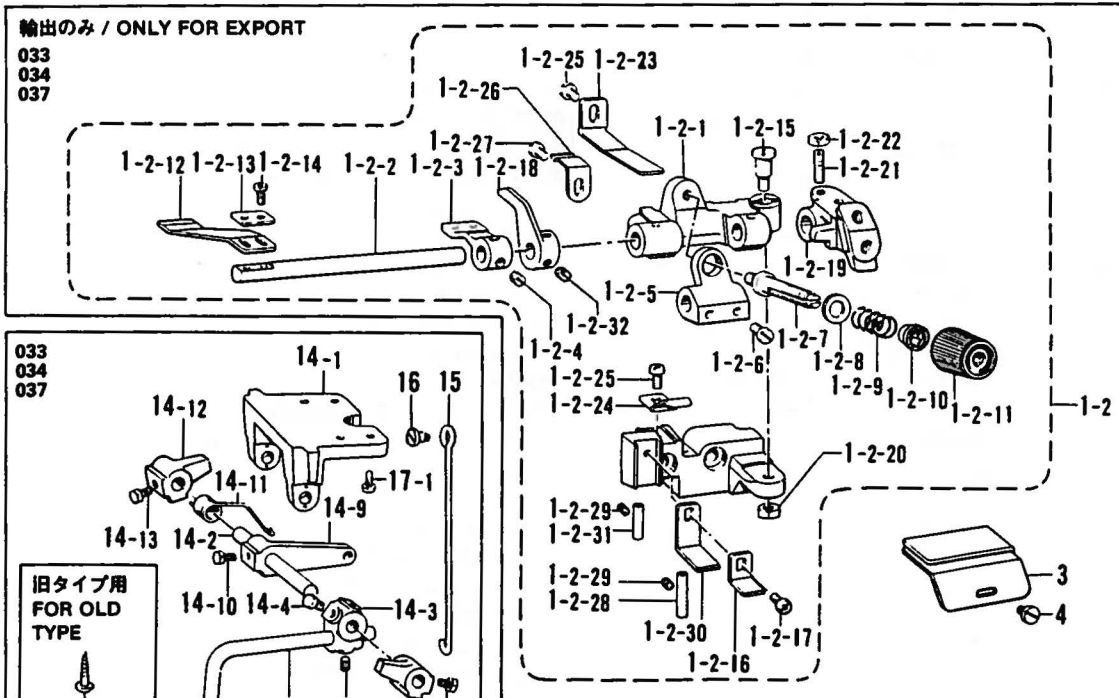
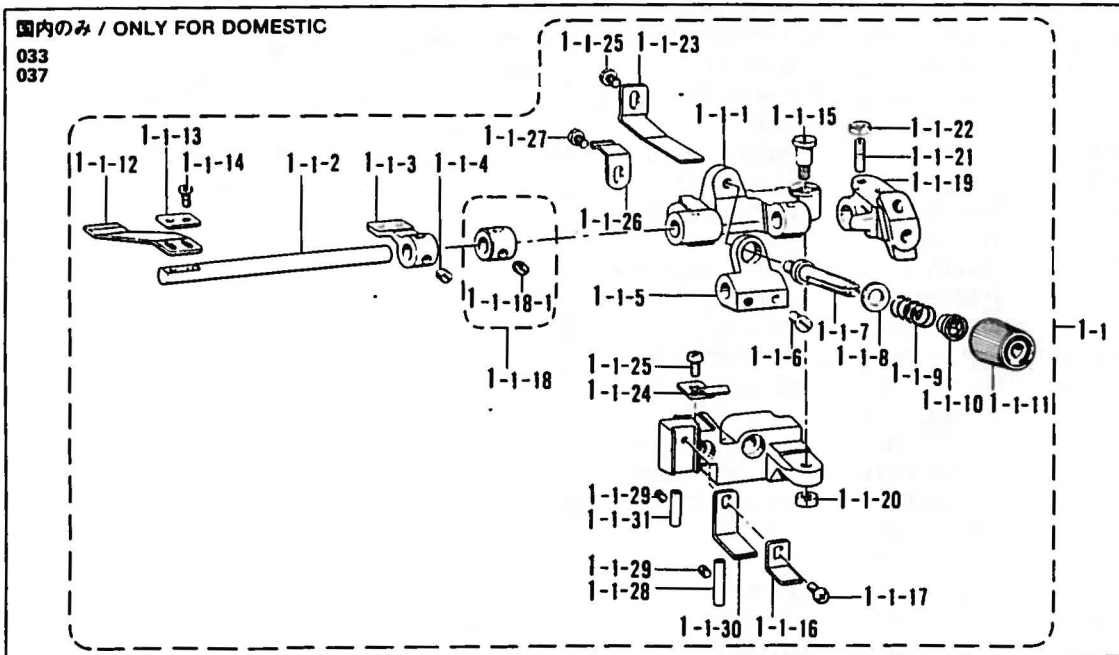



H. ラフラー装置関係/Ruffling attachment/Kräuselvorrichtung/  
Accessoire pour fronces/Accessorio de fruncido

REF.NO	CODE	Q'TY	品名	NAME OF PARTS	RMKS
1-2-29	013679412	2	-----	SCREW	
1-2-30	154795001	1	-----	RUFFLING BLADE GUIDE PLATE (LOWER)	
1-2-31	S01614001	1	-----	THREAD GUIDE PIPE	
1-2-32	101706001	2	-----	SCREW 6.35	
3	144793000	1	-----	RUFFLER GUIDE	
4	112751002	1	-----	SCREW 3.57	
14	155196209	1	サト"ウチヨウセツソウチクミ	DIFFERENTIAL ADJUSTMENT ASSEMBLY	
14-1	155197001	1	ヒサ"アテヨコシ"クウケ	KNEE LIFTER SHAFT BRACKET	
14-2	155198101	1	ヨコシ"ク	KNEE LIFTER SHAFT	
14-3	155199101	1	ヒサ"アテツキ"テ	KNEE LIFTER BRACKET	
14-4	017781012	2	ボ"ルト6.35X10	BOLT 6.35X10	
14-5	148797001	1	ヒサ"アゲ"ダテシ"クS	KNEE LIFTER BAR (SMALL)	
14-6	014780622	1	アナトメネシ"6.35クボ"ミ	SCREW 6.35	
14-7	148798009	1	ヒサ"アテL	KNEE LIFTER PLATE (LARGE)	
14-8	100463001	1	4カクボ"ルト7.94	BOLT 7.94	
14-9	155201101	1	ヒサ"アテレハ"ー	KNEE LIFTER LEVER	
14-10	017781012	2	ボ"ルト6.35X10	BOLT	
14-11	155202001	1	ヒサ"アテレハ"ーハ"ネ	KNEE LIFTER LEVER SPRING	
14-12	155203201	2	ヨコシ"クトメク"	COLLAR	
14-13	017781012	4	ボ"ルト6.35X10	BOLT 6.35X10	
15	155205001	1	ヒサ"アテリンク	CONNECTING BAR	
16	146594001	1	タ"ンネシ"4.76	STUD SCREW 4.76	
17-1	062681012	4	ナヘ"コ437-40X10	SCREW 437X10	
17-2	032422505	4	+マルモクネシ"4.1X25 <キュータイプ" トウフ"ウケヨウ>	SCREW 4.1X25 <FOR OLD TYPE HEAD BRACKET>	

H. ラフラー装置関係/Ruffling attachment/Kräuselvorrichtung/  
 Accessoire pour fronces/Accesorio de fruncido

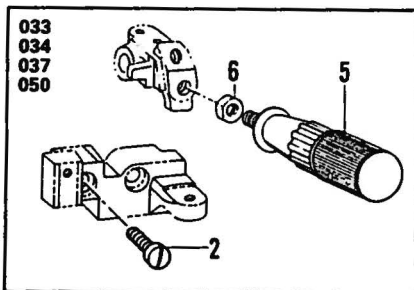
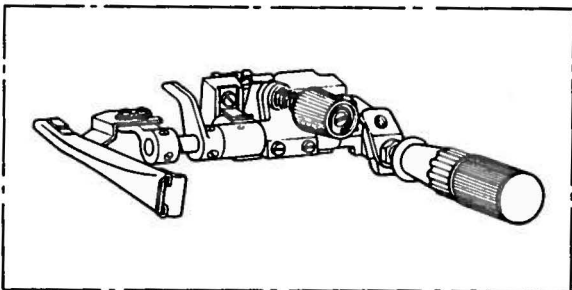
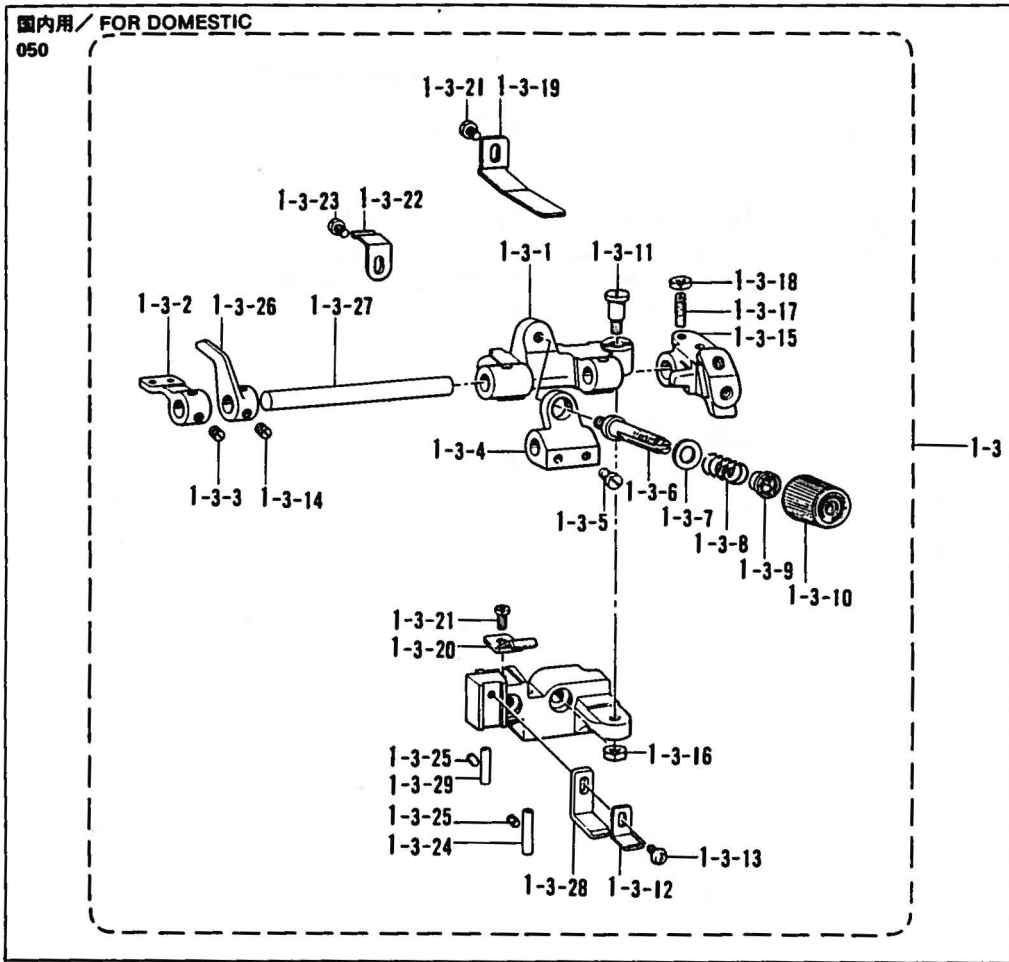
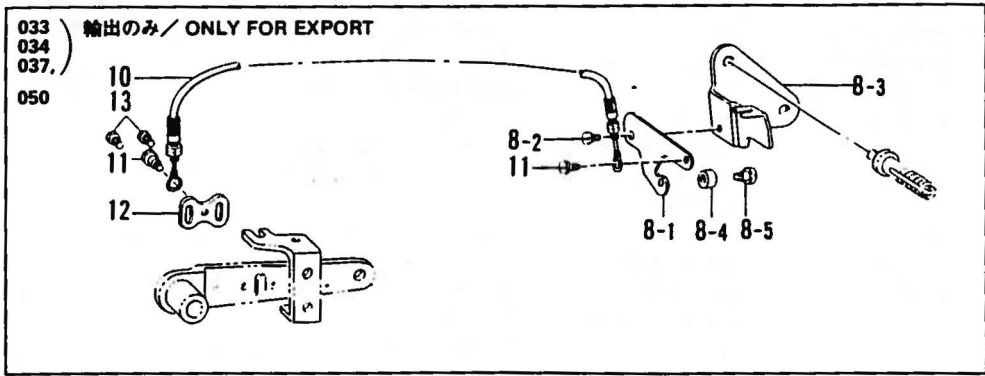

H. ラフラー装置関係/Ruffling attachment/Kräuselvorrichtung/  
Accessoire pour fronces/Accessorio de fruncido

REF.NO.	CODE	QTY	ヒンメイ	NAME OF PARTS	RMKS
1-3	149202209	1	ラツハート"タ"イクミ	-----	
1-3-1	146588001	1	キシ"オサエタイ	-----	
1-3-2	146589001	1	ラツハート"タ"イ	-----	
1-3-3	101706001	2	トメネジ"6.35	-----	
1-3-4	146590001	1	ハ"ネウク	-----	
1-3-5	105163001	2	アタマツキトメネジ"5.95	-----	
1-3-6	110820101	1	イトチヨウシホ"ウ	-----	
1-3-7	025770232	1	ヒラサ"カ"ネチユウ6.35	-----	
1-3-8	144788001	1	キシ"オサエハ"ネ	-----	
1-3-9	144105000	1	チヨウシハ"ネウエサ"ガ"ネ	-----	
1-3-10	149566009	1	イトチヨウシナツト	-----	
1-3-11	147933001	1	タ"ンネジ"5.95	-----	
1-3-12	145807001	1	キシ"オサエタイアンナイ	-----	
1-3-13	062680812	1	ナヘ"コ437-40X8	-----	
1-3-14	101706001	2	トメネジ"6.35	-----	
1-3-15	145810001	1	ハント"ルトリツケイタ	-----	
1-3-16	150553002	1	ナツト5.95	-----	
1-3-17	110230001	1	トメネジ"4.37	-----	
1-3-18	105234003	1	ナツト4.37	-----	
1-3-19	145811001	1	ハント"ルモト"シイタハ"ネ	-----	
1-3-20	145808001	1	キシ"オサエタイメハ"ネ	-----	
1-3-21	062680612	2	ナヘ"コ4.37-40X6	-----	
1-3-22	144764001	1	マエフタトメイタハ"ネ	-----	
1-3-23	060670512	1	ハ"イント"357-40X5	-----	
1-3-24	146592001	1	イトアンナイハ"イフ"	-----	
1-3-25	013679412	2	トメネジ"3.57クホ"ミ	-----	
1-3-26	148387001	1	キシ"オサエアケ"	-----	
1-3-27	149203001	1	ラツハート"タ"イシ"ク	-----	
1-3-28	154795001	1	キシ"オサエタイアンナイD	-----	
1-3-29	S01614001	1	イトアンナイハ"イフ"	-----	
2	S01304001	2	シメネジ"6.35X18	SCREW 6.35X18	
5	145809001	1	ハント"ル	HANDLE	
6	150556002	1	ナツト6.35	NUT 6.35	
8	148395001	1	キシ"オサエアケ"レハ"ークミ	RUFFLING PLATE LIFTER LEVER ASSEMBLY	
8-1	148388001	1	キシ"オサエアケ"レハ"ー	RUFFLING PLATE LIFTER LEVER	
8-2	141514001	1	ハサミタ"ンネジ"	STUD SCREW	
8-3	148389001	1	オサエアケ"レハ"ーササエ	PRESSER FOOT LIFTER LEVER SUPPORTER	
8-4	148390001	1	コロ	ROLLER	
8-5	112301001	1	タ"ンネジ"3.18	STUD SCREW 3.18	
10	148391001	1	フレキシブルワイヤクミ	FLEXIBLE WIRE ASSEMBLY	
11	141514001	2	ハサミタ"ンネジ"	STUD SCREW	
12	147672001	1	ワイヤトリツケイタ	WIRE SETTING PLATE	
13	062670612	2	ナヘ"コ357-40X6	SCREW 357X6	



J. ヒモ案内関係 / Gimp guide mechanism / Schnurführung /  
 Mécanisme du guide-fil / Mecanismo guía del hilo

037  
 050

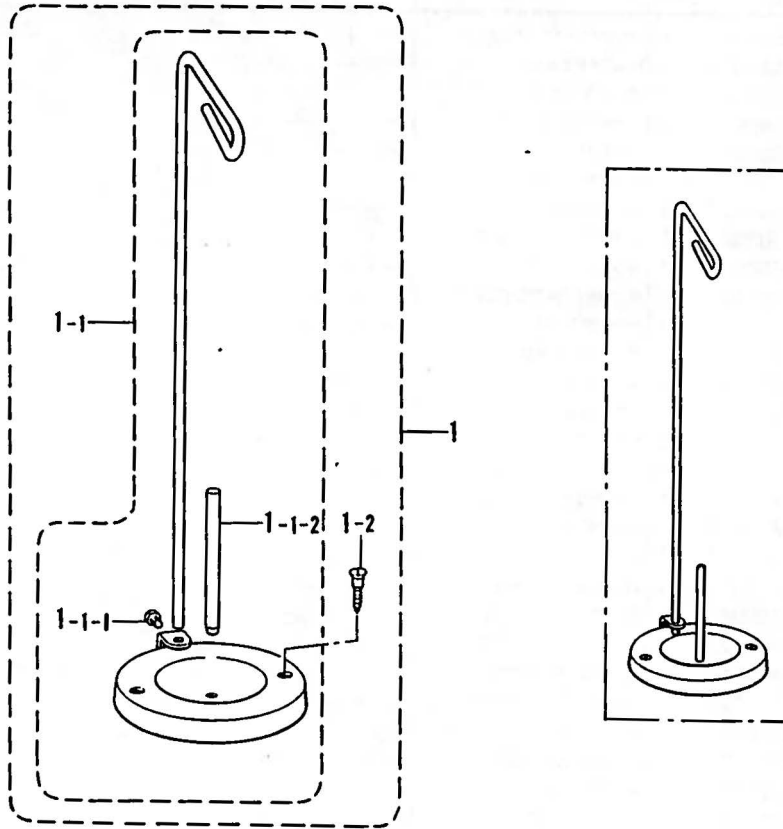

K. テープワインダー関係 / Tape winder mechanism / Bandaufwickelvorrichtung /  
 Mécanisme de l'enrouleur de ruban / Mecanismo bobinador de cinta

037  
 050  
 056

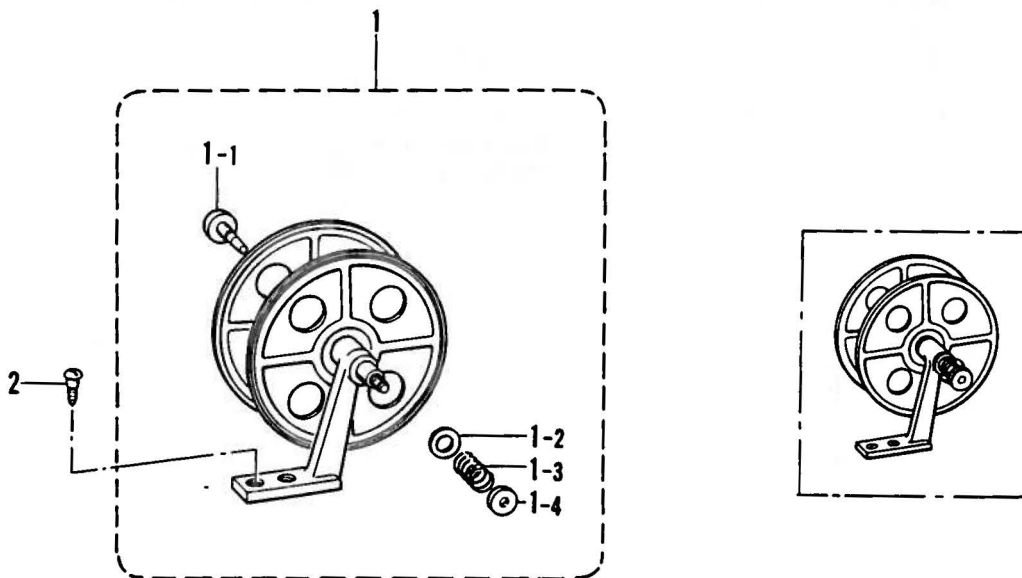

J. ヒモ案内関係 / Gimp guide mechanism / Schnurführung /  
 Mécanisme du guide-fil / Mecanismo guía del hilo

REF. NO.	CODE	Q'TY	ヒンメイ	NAME OF PARTS	RMKS
1	S20130009	1	イトタテダ"イクミネシ"ツキ	COTTON STAND ASSEMBLY WITH SCREW	
1-1	S20131009	1	イトタテダ"イクミ	SPOOL STAND ASSEMBLY	
1-1-1	S20134001	1	シメネシ"W476-24X10	SCREW W476X10	
1-1-2	S20135001	1	イトタテホ"ウ	SPOOL STUD	
1-2	035412006	2	マルサラモクネシ"4.1X20	SCREW 4.1X20	

K. テープワインダー関係 / Tape winder mechanism / Bandaufwickelvorrichtung /  
 Mécanisme de l'enrouleur de ruban / Mecanismo bobinador de cinta

REF. NO.	CODE	Q'TY	ヒンメイ	NAME OF PARTS	RMKS
1	143767002	1	テープワインダ"ークミ	TAPE WINDER ASSEMBLY	
1-1	143980001	1	ツマミネシ"	THUMB SCREW	
1-2	108494001	1	サ"カ"ネ	WASHER	
1-3	108495001	1	テープワインダ"オシハ"ネ	SPRING	
1-4	100136001	1	イトチヨウシナツト	TENSION CONTROL NUT	
2	101118001	2	マルモクネシ"4.5X20	SCREW 4.5X20	

L. ラッパー関係 / Lapper mechanism / Falz-Mechanismus /  
 Mécanisme à rabat / Mecanismo de solapado

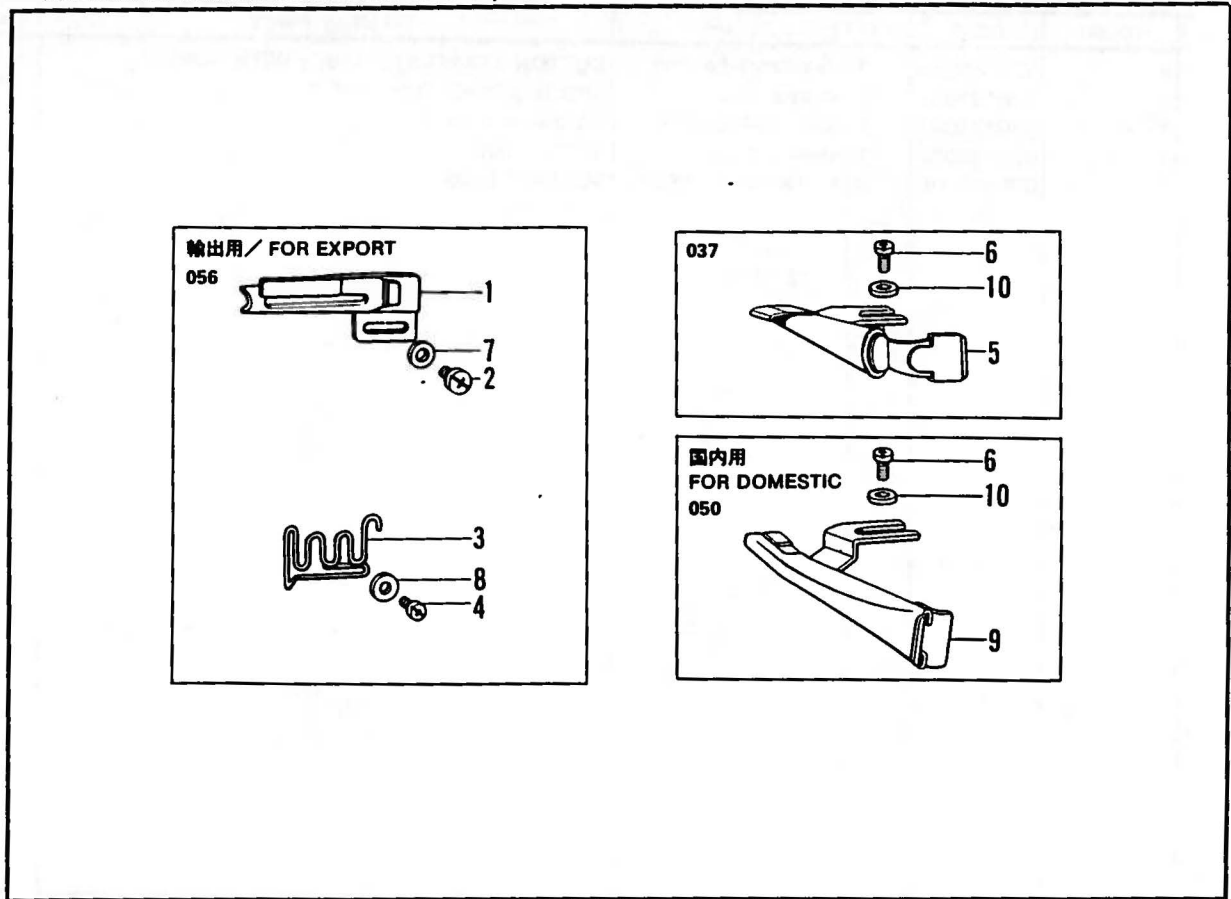

M. バックタック関係 / Back-tacking / Rückwärtsheftvorrichtung /  
 Point d'arrêt / Pespunte de revés

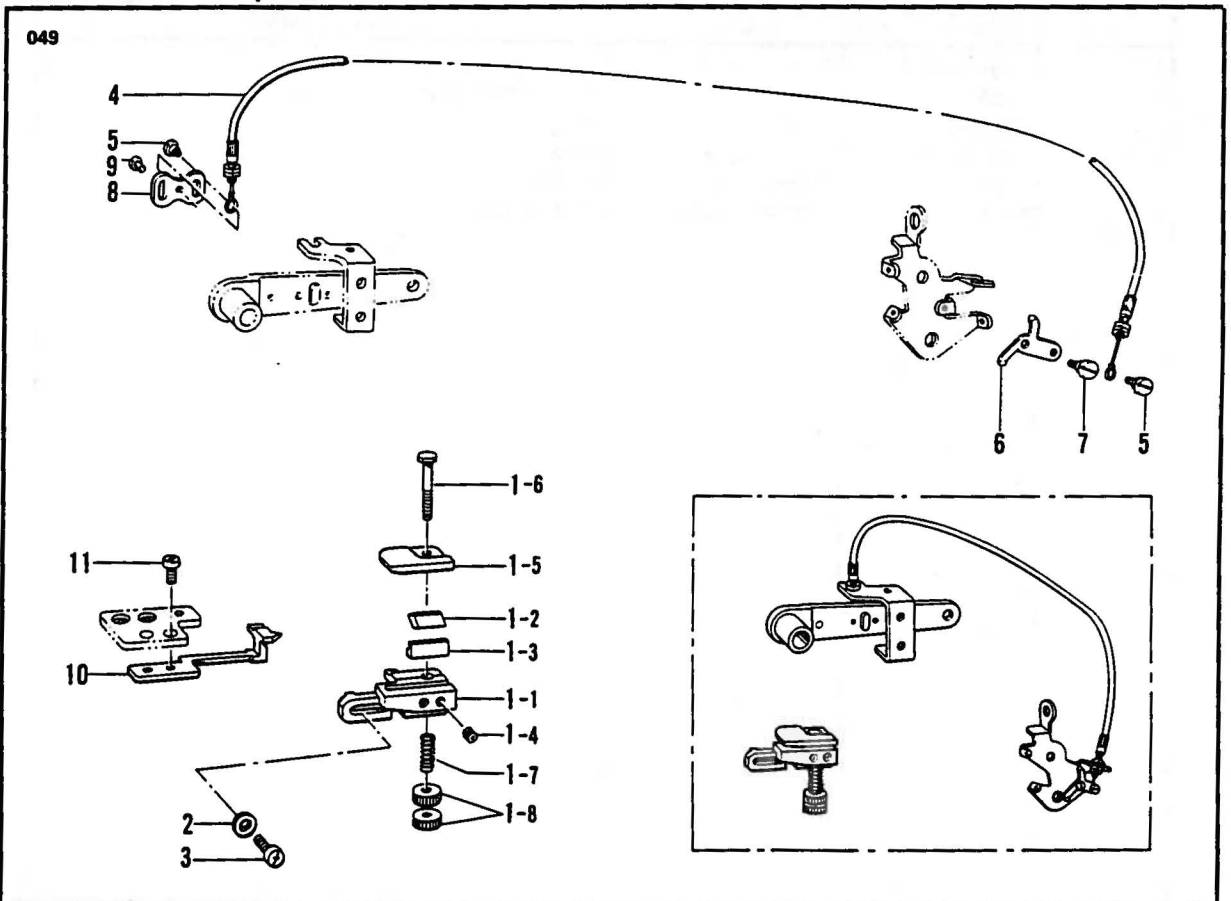



L. ラッパ-関係 / Lapper mechanism / Falz-Mechanismus /  
Mécánisme à rabat / Mecanismo de solapado

REF.NO.	CODE	Q'TY	ヒンメイ	NAME OF PARTS	RMKS
1	147373000	1	-----	LAPPER ASSEMBLY	
2	062670512	2	-----	SCREW 357X5	
3	147377001	1	-----	TAPE GUIDE	
4	062670512	2	-----	SCREW 357X5	
5	147440000	1	ラツハ-クミ	LAPPER ASSEMBLY	
6	062680612	2	ナヘ"コ4.37-40X6	SCREW 437X6	
7	105161004	2	-----	WASHER	
8	025350332	2	-----	WASHER 3.5	
9	149197000	1	ラツハ-クミ(18-20)	-----	
10	110735002	2	ザ"ガ"ネ	WASHER	

M. バックタツク関係 / Back-tacking / Rückwärtsheftvorrichtung /  
Point d'arrêt / Pespunte de revés

REF.NO.	CODE	Q'TY	ヒンメイ	NAME OF PARTS	RMKS
1	S09232101	1	カエシヌイオサエクミ	BACK-TACK PRESSER ASSEMBLY	
1-1	S09233001	1	カエシヌイメスト"タイ	BACK-TACK KNIFE HOLDER	
1-2	S09234001	1	カエシヌイメス	BACK-TACK KNIFE	
1-3	S09235001	1	カエシヌイメスオサエ	BACK-TACK KNIFE PRESSER	
1-4	146427001	2	アナムネシ"3.18クホ"ミ	SCREW 3.18	
1-5	S11144001	1	カエシヌイオサエイタ	BACK-TACK PRESSER PLATE	
1-6	S09237101	1	オサエイタオシホ"ウ	PRESSER PLATE SHAFT	
1-7	116794001	1	オシハ"ネ	SPRING	
1-8	107682001	2	イトマキチヨウシナツト	TENSION CONTROL NUT	
2	025350132	2	ヒラサ"カ"ネシヨウ	WASHER	
3	062671012	2	ナヘ"コ357-40X10	SCREW 357X10	
4	147480001	1	フレキシブルワイヤクミ	FLEXIBLE WIRE ASSEMBLY	
5	141514001	2	ハサミタ"ンネシ"	STUD SCREW	
6	148371001	1	イトユルメテコ	THREAD RELEASE LEVER	
7	141514001	1	ハサミタ"ンネシ"	STUD SCREW	
8	147672001	1	ワイヤトリツケイタ	WIRE PLATE	
9	062670612	2	ナヘ"コ357-40X6	SCREW 357X6	
10	S11121001	1	イトサハ"キ	LOOP SPREADING	
11	062660412	2	ナヘ"コ318-40X4	SCREW 318X4	

N. 上ルーバ関係/Over looper mechanism/Oberen Greifer/  
 Mécanisme du boucleur supérieur/Mecanismo del presilladora superior

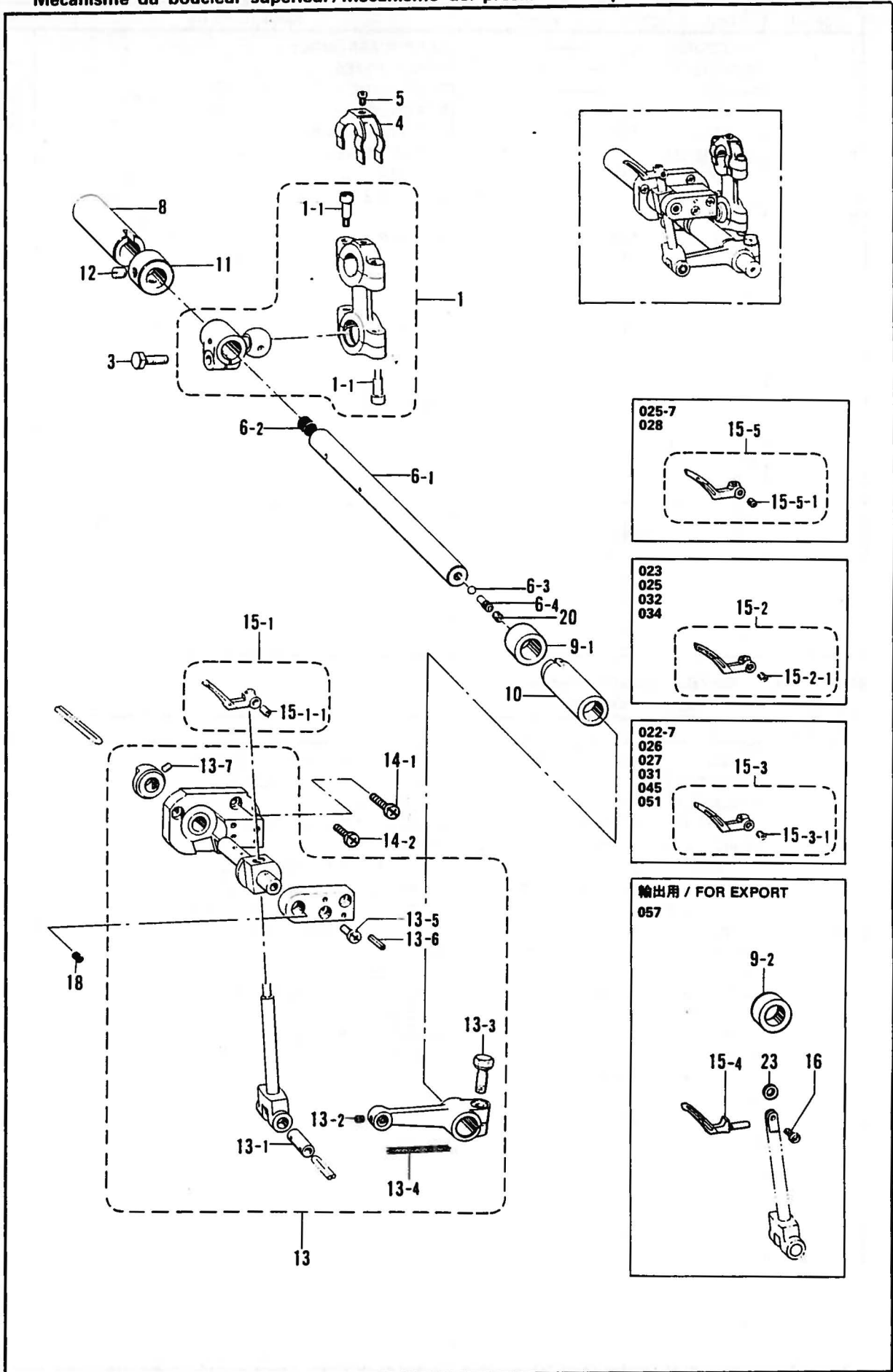

N. 上ルーバ関係/Over looper mechanism/Oberen Greifer/  
 Mécanisme du boucleur supérieur/Mecanismo del presilladora superior

REF NO.	CODE	Q'TY	ヒンメイ	NAME OF PARTS	RMKS
1	144025001	1	ウフルーハ"ロツト"クミ	OVER LOOPER CONNECTING ROD ASSEMBLY	※
1-1	148425001	4	アナボ"ルト4.37X14	BOLT 4.37X14	
3	017771412	1	ボ"ルト6.35X14	BOLT 6.35X14	
4	110704001	1	ウフルーハ"ロツト"フレ"ト"メ	LOOPER CONNECTING ROD STOPPER	
5	062660412	1	ナヘ"コ318-40X4	SCREW 318X4-	
6	S06294001	1	ウフルーハ"シ"ククミ	OVER LOOPER SHAFT ASSEMBLY	
6-1	148033001	1	ウフルーハ"シ"ク	OVER LOOPER SHAFT	
6-2	140327001	1	ゴ"ムセン	OIL CAP	
6-3	071023850	1	コウキユウ3/32	STEEL BALL 3/32"	
6-4	148034001	1	オイルチヨウセツネシ"	OIL ADJUSTING SCREW	
8	144029000	1	ウフルーハ"シ"クメタルB	OVER LOOPER SHAFT BUSHING (REAR)	
9-1	146602001	1	ウフルーハ"シ"クカラ-	THRUST COLLAR	
9-2	S01597001	1	-----	THRUST COLLAR	
10	144031000	1	ウフルーハ"シ"クメタルF	OVER LOOPER SHAFT BUSHING (FRONT)	
11	146581001	1	セツトカラ-	SET COLLAR	
12	100260001	2	トメネシ"5.95	SCREW 5.95	
13	*	1	ウフルーハ"キ"コウクミ	OVER LOOPER ASSEMBLY	
13-1	148379001	1	ウフルーハ"ウデ"シ"ク	OVER LOOPER HOLDING SHAFT	
13-2	148294001	1	アナトメネシ"3.57クホ"ミ	SCREW 3.57	
13-3	149170001	1	ボ"ルト6.35X16	BOLT 6.35X16	
13-4	140416000	1	クミヒモ	WICK	
13-5	062681012	2	ナヘ"コ437-40X10	SCREW 437X10	
13-6	047301440	2	スフ"リンク"ヒ"ンAW3	SPRING PIN AW3	
13-7	014680422	2	アナトメネシ"4.37クホ"ミ	SCREW 4.37	
14-1	062680712	1	ナヘ"コ437-40X7	SCREW 437X7	
14-2	S10774001	2	ナヘ"コ437-40X7	SCREW 437X7	
15-1	147934001	1	ウフルーハ"ネシ"ツキ	OVER LOOPER WITH SCREW	
15-1-1	014680422	1	アナトメネシ"4.37クホ"ミ	SCREW 4.37	
15-2	147936001	1	ウフルーハ"ネシ"ツキ <1ホンハズ"シヨウ>	OVER LOOPER <FOR MOCK SAFETY>	
15-2-1	014680422	1	アナトメネシ"4.37クホ"ミ	SCREW 4.37	
15-3	159686001	1	ウフルーハ"ネシ"ツキ	OVER LOOPER WITH SCREW	
15-3-1	014680422	1	アナトメネシ"4.37クホ"ミ	SCREW 4.37	
15-4	S01465001	1	-----	OVER LOOPER	
15-5	S16496001	1	-----	OVER LOOPER WITH SCREW	
15-5-1	014680422	1	-----	SCREW 4.37	
16	062660612	1	-----	SCREW 3.18X6	
18	159101000	1	メクラセン	OIL CAP	
20	148294001	1	アナトメネシ"3.57クホ"ミ	SCREW 3.57	
23	S01675001	1	-----	SPACER	

※クドウジク Aクミ (B-1-1, D-1, N-1, P-1) 146915-001

※Crank Shaft (A) Assembly (B-1-1, D-1, O-1, R-1) 146915-(R)1  
 ※Crank Shaft (B) Assembly (B-1-2, D-1, O-1, R-1) 150874-(R)1



P. 下ルーバ関係/Under looper mechanism/Unterer Greifer/  
 Mécanisme du boucleur inférieur/Mecanismo del presilladora inferior

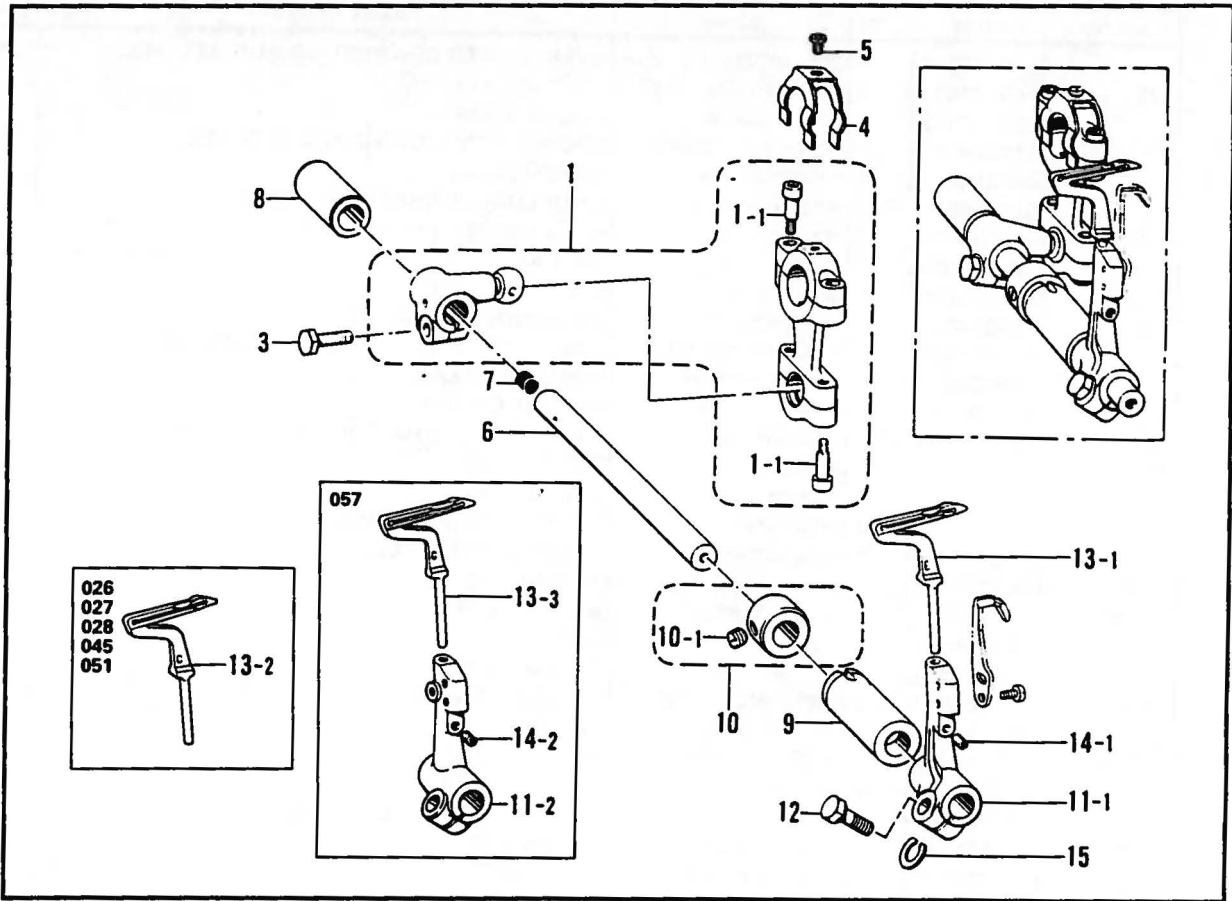

P. 下ルーバ関係/Under looper mechanism/Unterer Greifer/  
 Mécanisme du boucleur inférieur/Mecanismo del presilladora inferior.

REF NO.	CODE	Q'TY	ヒンメイ	NAME OF PARTS	RMKS
1	144044001	1	シタルーハ*ロツト*クミ	UNDER LOOPER ROD ASSEMBLY	*
1-1	148425001	4	アナボルト4.37X14	BOLT 4.37X14	
3	017771612	1	ボルト6.35X16	BOLT 6.35X16	
4	110704001	1	ウフルーハ*ロツト*フレツメ	LOOPER CONNECTING ROD STOPPER	
5	062660412	1	ナヘ"ユ318-40X4	SCREW 318X4	
6	146614001	1	シタルーハ*シク	UNDER LOOPER SHAFT	
7	140327001	1	ゴムセン	OIL CAP	
8	146615000	1	シタルーハ*シクメタルB	UNDER LOOPER SHAFT BUSHING (REAR)	
9	146616000	1	シタルーハ*シクメタルF	UNDER LOOPER SHAFT BUSHING (FRONT)	
10	180323001	1	シタシクセツカラクミ	LOWER SHAFT SET COLLAR ASSEMBLY	
10-1	013760612	2	トメネシ"5.95クボ"ミ	SCREW 5.95	
11-1	146617001	1	シタルーハ*ドリツケタイ	UNDER LOOPER HOLDER	
11-2	S01431001	1	-----	UNDER LOOPER HOLDER	
12	149171001	1	ボルト5.56X14	BOLT 5.56X14	
13-1	S01248101	1	シタルーハ*	UNDER LOOPER	
13-2	159884101	1	シタルーハ*	UNDER LOOPER	
13-3	S01432101	1	-----	UNDER LOOPER	
14-1	014680422	1	アナトメネシ"4.37クボ"ミ	SCREW 4.37	
14-2	014680422	2	-----	SCREW 4.37	
15	148782001	1	スペーサ	SPACER	
*クドウジク A クミ (B-1-1, D-1, N-1, P-1) 146915-001				* Crank Shaft (A) Assembly (B-1-1, D-1, O-1, R-1) 146915-001 * Crank Shaft (B) Assembly (B-1-2, D-1, O-1, R-1) 150874-001	

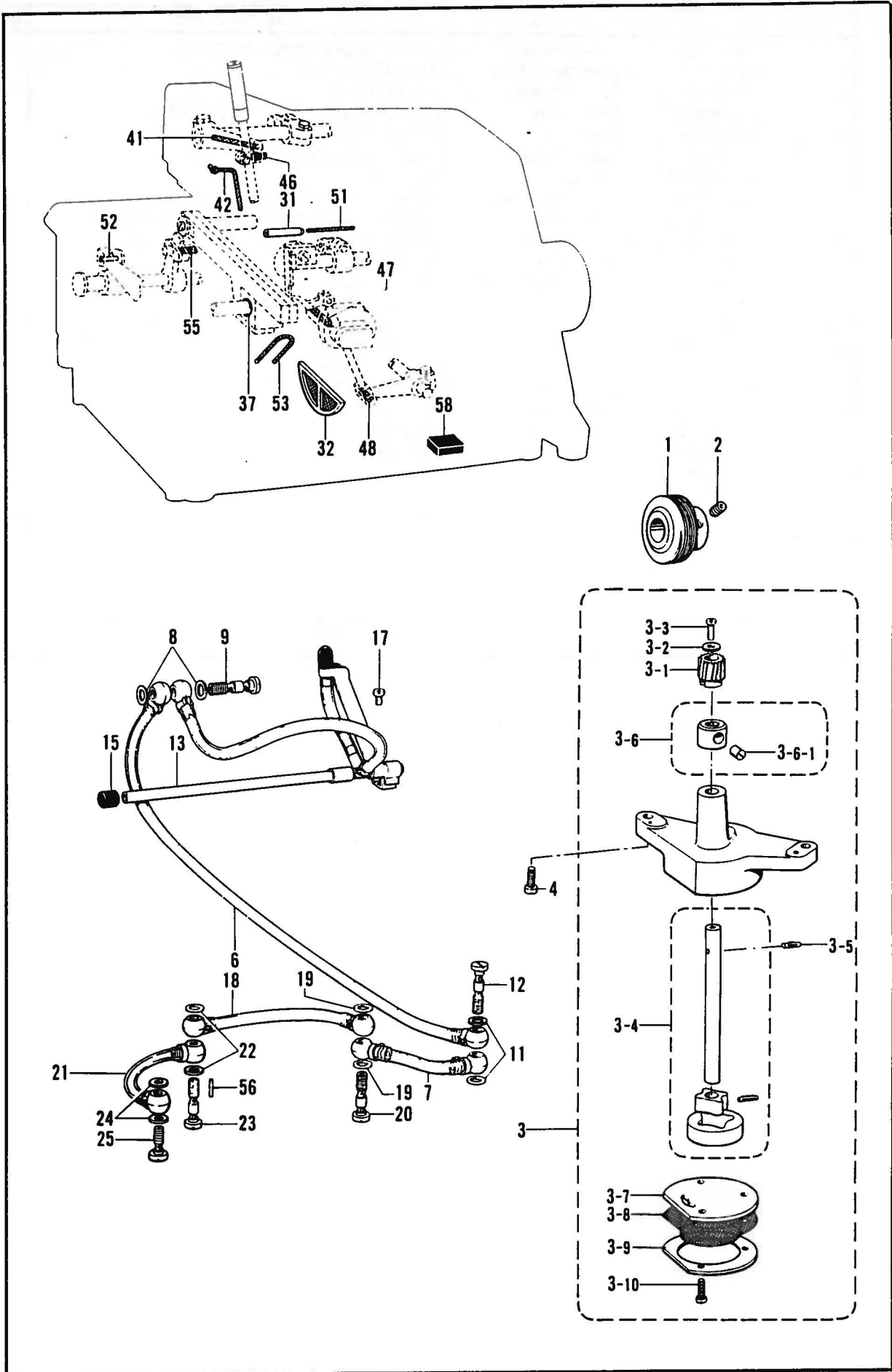



Q. 給油・潤滑関係/Lubrication /Schmierung /Lubrification /Lubricación

REF NO	CODE	Q'TY	品名	NAME OF PARTS	RMKS
1	146647001	1	ウオーム	WORM	
2	014770622	2	アナトメネジ"6.35クホ"ミ	SCREW 6.35	
3	147521001	1	トロコイト"ポンプ"クミ	PUMP ASSEMBLY	
3-1	144619000	1	ウオームホイール	WORM WHEEL	
3-2	025350332	1	ヒラサ"カ"ネタ"イ3.5	WASHER 3.5	
3-3	062670812	1	ナヘ"コ357-40X8	SCREW 357X8	
3-4	147523001	1	ポンプ"ローター"クミ	PUMP INNER ROTER ASSEMBLY	
3-5	144622001	1	ミノ"ツキ"ピンE"カ"タ	DOWEL PIN (E)	
3-6	181995001	1	セット"カラ"クミ	SET COLLAR ASSEMBLY	
3-6-1	101706001	2	トメネジ"6.35	SCREW 6.35	
3-7	147527001	1	ポンプ"フタ	PUMP COVER	
3-8	147528100	1	ロカモウ	OIL FILTER	
3-9	147529001	1	ロカモウ"オサエ	OIL FLANGE FILTER	
3-10	062671012	3	ナヘ"コ357-40X10	SCREW 357X10	
4	062711212	2	ナヘ"コ476-32X12	SCREW 476X12	
6	140780101	1	ビ"ニル"チューブ"クミ	VINYL TUBE ASSEMBLY	
7	140779101	1	ビ"ニル"チューブ"クミ	VINYL TUBE ASSEMBLY	
8	112348001	2	ハ"ツキン	PACKING	
9	112364001	1	ハイユ"ハ"イフ"ツキ"テネジ"	SCREW	
11	112348001	2	ハ"ツキン	PACKING	
12	112364001	1	ハイユ"ハ"イフ"ツキ"テネジ"	SCREW	
13	146636201	1	ロット"オイル"ハ"イフ"クミ	MAIN OIL PIPE ASSEMBLY	
15	140325001	1	ゴム"セ"	OIL CAP	
17	062670612	1	ナヘ"コ357-40X6	SCREW 357X6	
18	140778101	1	ビ"ニル"チューブ"クミ	VINYL TUBE ASSEMBLY	
19	112348001	2	ハ"ツキン	PACKING	
20	112364001	1	ハイユ"ハ"イフ"ツキ"テネジ"	SCREW	
21	147211101	1	ビ"ニル"チューブ"クミ	VINYL TUBE ASSEMBLY	
22	112348001	2	ハ"ツキン	PACKING	
23	112364001	1	ハイユ"ハ"イフ"ツキ"テネジ"	SCREW	
24	112348001	2	ハ"ツキン	PACKING	
25	112359001	1	ハイユ"ハ"イフ"ツキ"テネジ"	SCREW	
31	147217000	1	オイル"ハ"イフ"	OIL PIPE	
32	145664000	1	オイル"フィルタ"	OIL FILTER	
37	114294001	1	リング"	O RING	
41	140418000	1	クミ"ヒモ	WICK	
42	150307000	1	クミ"ヒモ	WICK	
46	140415000	2	クミ"ヒモ	WICK	
47	140317000	1	クミ"ヒモ	WICK	
48	140417000	1	クミ"ヒモ	WICK	
51	112735000	1	クミ"ヒモ	WICK	
52	147318000	1	ピン	PIN	
53	147361000	1	クミ"ヒモ	WICK	
55	147363000	1	フェルト	FELT	
56	147318000	1	ピン	PIN	
58	112525000	1	シユウ"ジ"ン"マグ"ネット	MAGNET	

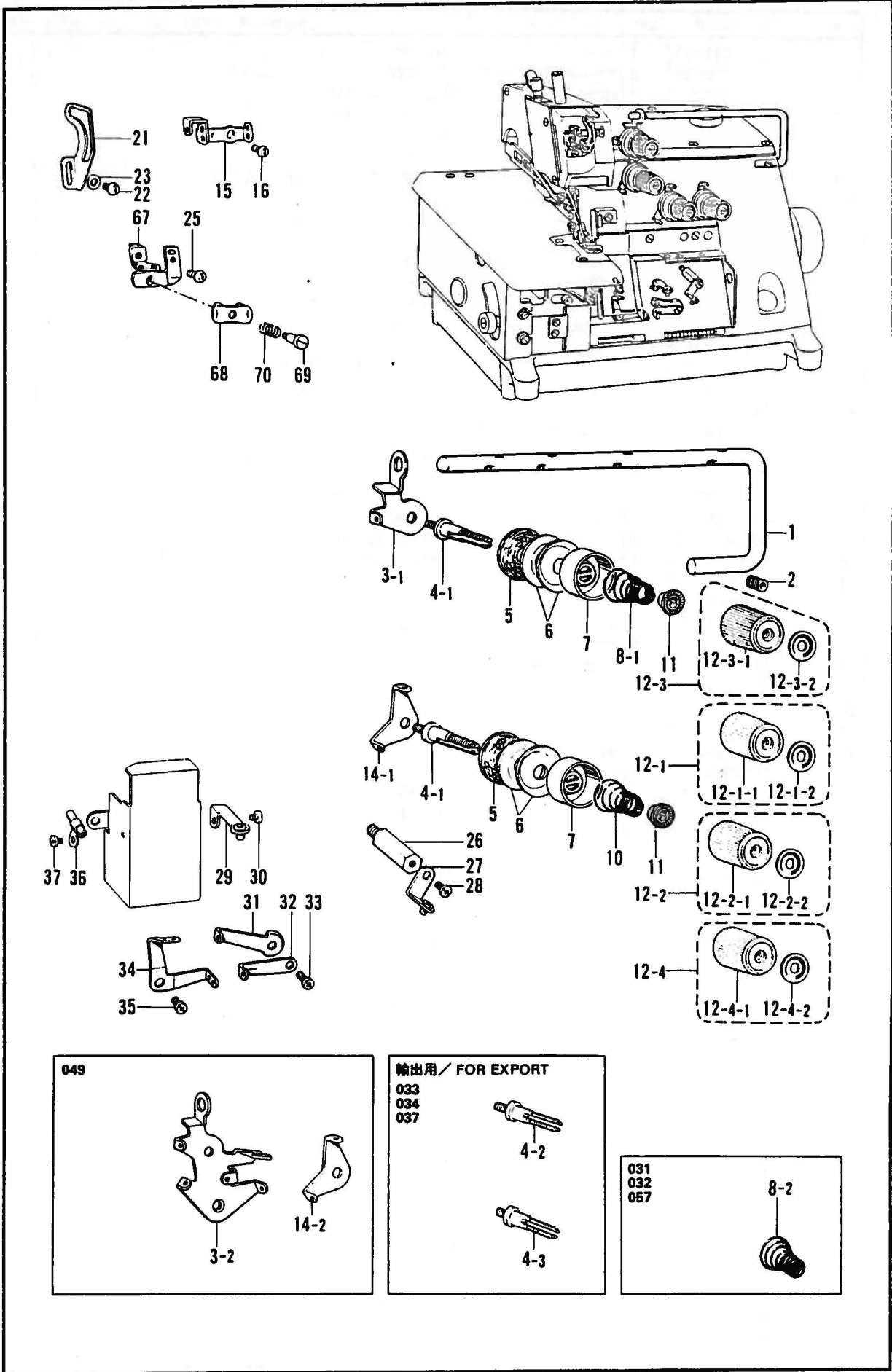

R. 糸調子関係/Thread tension/Faderspannung/Tension du fil/Tension del hilo

REF.NO	CODE	Q'TY	品名	NAME OF PARTS	RMKS
1	146648001	1	シユイトアンナイ	MAIN THREAD GUIDE	
2	014770622	1	アナトメネシ"6.35クホ"ミ	SCREW 6.35	
3-1	146649001	1	イトアンナイササエ	THREAD GUIDE SUPPORTER	
3-2	148370001	1	イトアンナイササエ	THREAD GUIDE SUPPORTER	
4-1	110820101	4	イトチヨウシホ"ウ	TENSION CONTROL STUD	
4-2	159574101	2	-----	TENSION STUD	
4-3	110820101	2	-----	TENSION CONTROL STUD	
5	110832009	4	イトチヨウシサラフエルト	TENSION DISC FELT	
6	145446001	8	イトチヨウシサラ	TENSION DISC	
7	144103009	4	イトチヨウシサラオサエ	TENSION DISC PRESSER	
8-1	144104001	2	ハリイトチヨウシハ"ネ	TENSION SPRING	
8-2	148851001	2	ハリイトチヨウシハ"ネ	NEEDLE TENSION SPRING	
10	144110001	2	シタルーハ"イトチヨウシハ"ネ	TENSION SPRING	
11	144105000	4	チヨウシハ"ネウエサ"カ"ネ	TENSION SPRING WASHER	
12-1	S19901001	1	イトチヨウシナツクミ (ミス"イロ)	THREAD TENSION CONTROL NUT ASSEMBLY (LIGHT BLUE)	
12-1-1	149566009	1	イトチヨウシナツ	THREAD TENSION ADJUSTING NUT	
12-1-2	147049001	1	キヨウシ"ヤクハ"ン	TENSION INDICATING PLATE	
12-2	S19901002	1	イトチヨウシナツクミ (ミト"リ)	THREAD TENSION CONTROL NUT ASSEMBLY (GREEN)	
12-2-1	149566009	1	イトチヨウシナツ	THREAD TENSION ADJUSTING NUT	
12-2-2	147049002	1	キヨウシ"ヤクハ"ン	TENSION INDICATING PLATE	
12-3	S19901003	1	イトチヨウシナツクミ(アカ)	THREAD TENSION CONTROL NUT ASSEMBLY (RED)	
12-3-1	149566009	1	イトチヨウシナツ	THREAD TENSION ADJUSTING NUT	
12-3-2	147049003	1	キヨウシ"ヤクハ"ン	TENSION INDICATING PLATE	
12-4	S19901004	1	イトチヨウシナツクミ (キイ)	THREAD TENSION CONTROL NUT ASSEMBLY (YELLOW)	
12-4-1	149566009	1	イトチヨウシナツ	THREAD TENSION ADJUSTING NUT	
12-4-2	147049004	1	キヨウシ"ヤクハ"ン	TENSION INDICATING PLATE	
14-1	110813001	3	ハリイトアンナイ	NEEDLE THREAD GUIDE	
14-2	110813001	2	ハリイトアンナイ	NEEDLE THREAD GUIDE	
15	146793001	1	ニホンハ"リハリイトアンナイ	TWIN NEEDLE THREAD GUIDE	
16	062660412	1	ナヘ"コ318-40X4	SCREW 318X4	
21	144108001	1	ハリイトテンヒ"ン	NEEDLE THREAD TAKE-UP	
22	062660412	1	ナヘ"コ318-40X4	SCREW 318X4	
23	105248003	1	サ"カ"ネ	WASHER	
25	062670612	1	ナヘ"コ357-40X6	SCREW 357X6	
26	144111001	1	シタルーハ"イトアンナイササエ	UNDER LOOPER THREAD GUIDE HOLDER	
27	146926002	1	イトアンナイクミ	UNDER LOOPER THREAD GUIDE ASSEMBLY	
28	062670612	1	ナヘ"コ357-40X6	SCREW 357X6	
29	146929001	1	ウフルーハ"イトアンナイクミ	OVER LOOPER THREAD GUIDE ASSEMBLY	
30	062670612	1	ナヘ"コ357-40X6	SCREW 357X6	
31	146652001	1	ウフルーハ"テンヒ"ンR	OVER LOOPER THREAD TAKE-UP (RIGHT)	
32	146653001	1	シタルーハ"テンヒ"ンR	UNDER LOOPER THREAD TAKE-UP (RIGHT)	
33	062670812	1	ナヘ"コ357-40X8	SCREW 357X8	
34	146654001	1	ルーハ"ーテンヒ"ンL	LOOPER THREAD TAKE-UP (LEFT)	
35	062670612	1	ナヘ"コ357-40X6	SCREW 357X6	
36	142669002	1	イトアンナイハ"イフ"クミ	OVER LOOPER THREAD GUIDE PIPE ASSEMBLY	
37	060630312	1	ハ"イント"238-56X3	SCREW 2.38X3	
67	147344001	1	コチヨウシキトリツケタ"イクミ	NEEDLE THREAD TAKE-UP SUPPORTER	
68	112300001	1	ハリイトオサエ	NEEDLE THREAD PRESSER	
69	112301001	1	タ"ンネシ"3.18	STUD SCREW 3.18	
70	112299001	1	ハリイトアンナイオシハ"ネ	SPRING	



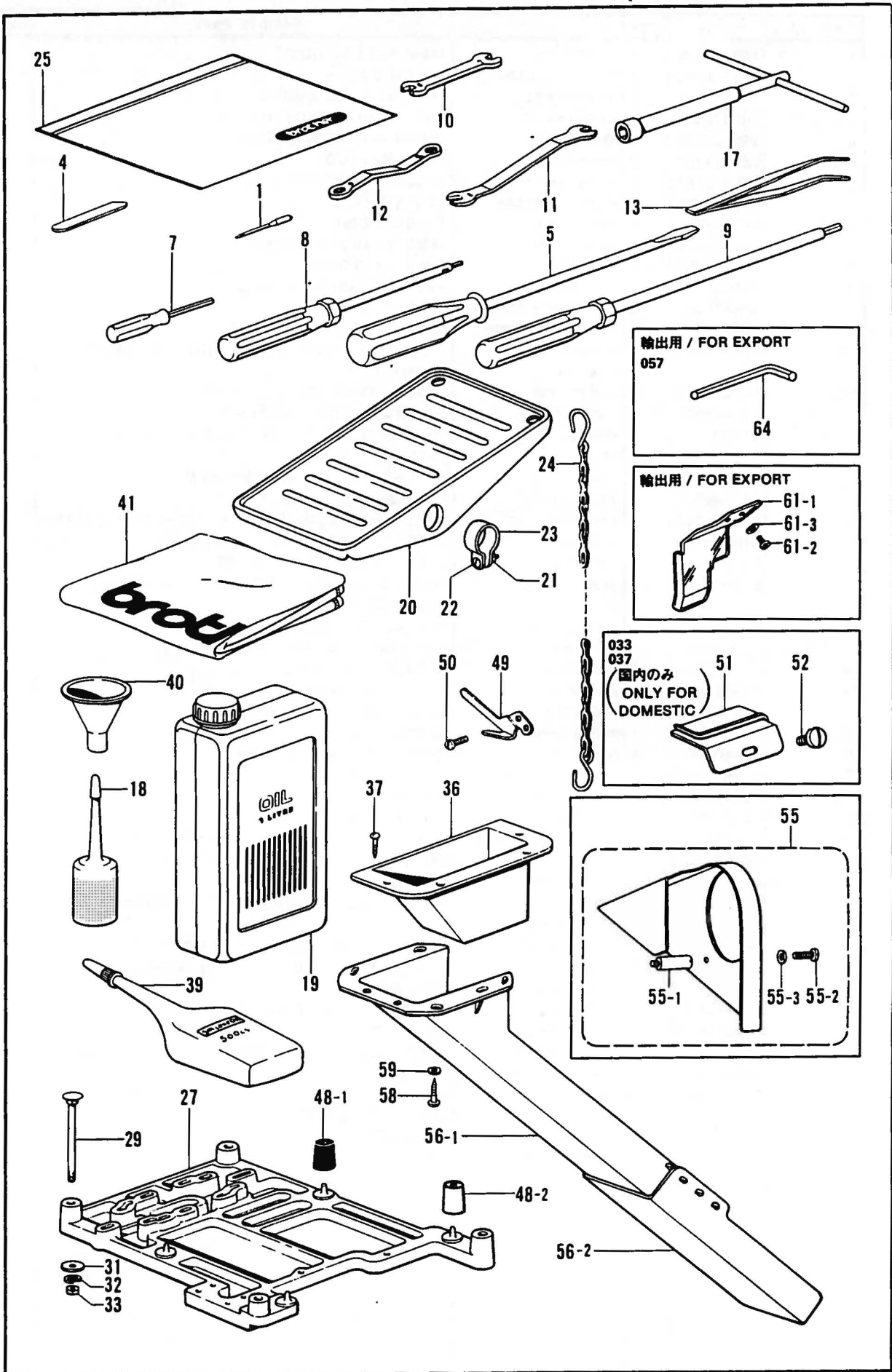

Z. 付属品関係 / Accessories / Zubehör / Accessoires / Accesorios

REF NO.	CODE	Q'TY	品名	NAME OF PARTS	RMKS
1	*	8	ミシンハリ	NEEDLE	
4	112436001	1	シタメス	LOWER KNIFE	
5	101572101	1	ネジ"マフシ"5.5X190	SCREW DRIVER 5.5X190	
7	S01943001	1	6カクホ"ウネシ"マフシ1.6	SCREW DRIVER 1.6	
8	146700001	1	6カクホ"ウネシ"マフシ2	SCREW DRIVER 2	
9	149173001	1	6カクホ"ウネシ"マフシ3	SCREW DRIVER 3	
10	107779001	1	スハ"ナ6X7	SPANNER 6X7	
11	143566001	1	スハ"ナ8	SPANNER 8	
12	105343001	1	メガ"ネレンチ8X9	WRENCH 8X9	
13	117466000	1	ピンセット	TWEEZERS	
17	140342001	1	ソケットレンチクミ	SOCKET WRENCH ASSEMBLY	
18	S06701000	1	ホ"リオイルクーキ	OILER ASSEMBLY	
19	145277105	1	オイルタンク	OIL TANK	
20	147893009	1	オサエアク"フミイタ	TREADLE PEDAL	
21	021400106	2	1シユナツト4	NUT 4	
22	062401406	2	ナヘ"コ4X14	SCREW 4X14	
23	116016001	2	ヘ"タルトメ	PEDAL STOPPER	
24	142262001	1	クサリフクミ	CHAIN (F) ASSEMBLY	
25	122991001	1	フソ"クヒンホ"リフクロ	ACCESSORY BAG	
27	S03888000	1	トウフ"ウケ	HEAD BRACKET	
29	210973001	4	カクネホ"ルト8X85	BOLT 8X85	
31	025080236	4	ヒラサ"カ"ネチユウ8	WASHER 8	
32	028080242	4	ハ"ネサ"カ"ネ2-8	SPRING WASHER 2-8	
33	021080106	4	ナツト1シユ8	NUT 8	
36	148430109	1	タ"スタート"ロツフ"	DUSTER DROP	
37	031311302	4	マルモクネシ"3.1X13	SCREW 3.1X13	
39	S06704001	1	シリコンオイル	SILICONE OIL	
40	140759000	1	シ"ヨーコ"	FUNNEL	
41	144225002	1	トウフ"カハ"ー	HEAD COVER	
48-1	147919001	1	ホ"ウシンゴム	CUSHION	
48-2	147919002	3	ホ"ウシンゴム	CUSHION	
49	140888001	1	カラヌイメス	TRIMMING KNIFE	
50	062660412	2	ナヘ"コ318-40X4	SCREW 318X4	
51	144793000	1	キシ"アンナイ	-----	
52	112751002	1	シメネシ"3.57	-----	
55	148348009	1	ヘ"ルトカハ"ークミ	BELT COVER ASSEMBLY	
55-1	148042001	2	ヘ"ルトカハ"ースタツト"	BELT COVER STUD	
55-2	062681012	2	ナヘ"コ437-40X10	SCREW 437X10	
55-3	100645003	2	サ"カ"ネ	WASHER	
56	183161209	1	タ"スター"シュートクミ	DUSTER SHOOT ASSEMBLY	
56-1	148431209	1	タ"スター"シュートL	DUSTER SHOOT (LARGE)	
56-2	148432009	1	タ"スター"シュートS	DUSTER SHOOT (SMALL)	
58	101118001	4	マルモクネシ"4.5X20	SCREW 4.5X20	
59	025050236	4	ヒラサ"カ"ネチユウ5	WASHER 5	
61	151017001	1	-----	EYE GUARD ASSEMBLY	
61-1	150550000	1	-----	EYE GUARD FOR OVERLOCK	
61-2	062660512	2	-----	SCREW 318X5	
61-3	025030232	2	-----	WASHER 3	
64	S01860001	1	-----	SPANNER 2	

※ 付属品の明細は変更することがあります。

※ The details of included accessories are subject to change.

※ Änderungen in der Aufstellung der Mitgelieferten Zubehöre sind vorbehalten.

※ Les détails des accessoires inclus sont sujets à des changements.

※ Los detalles de los accesorios incluidos pueden variar.

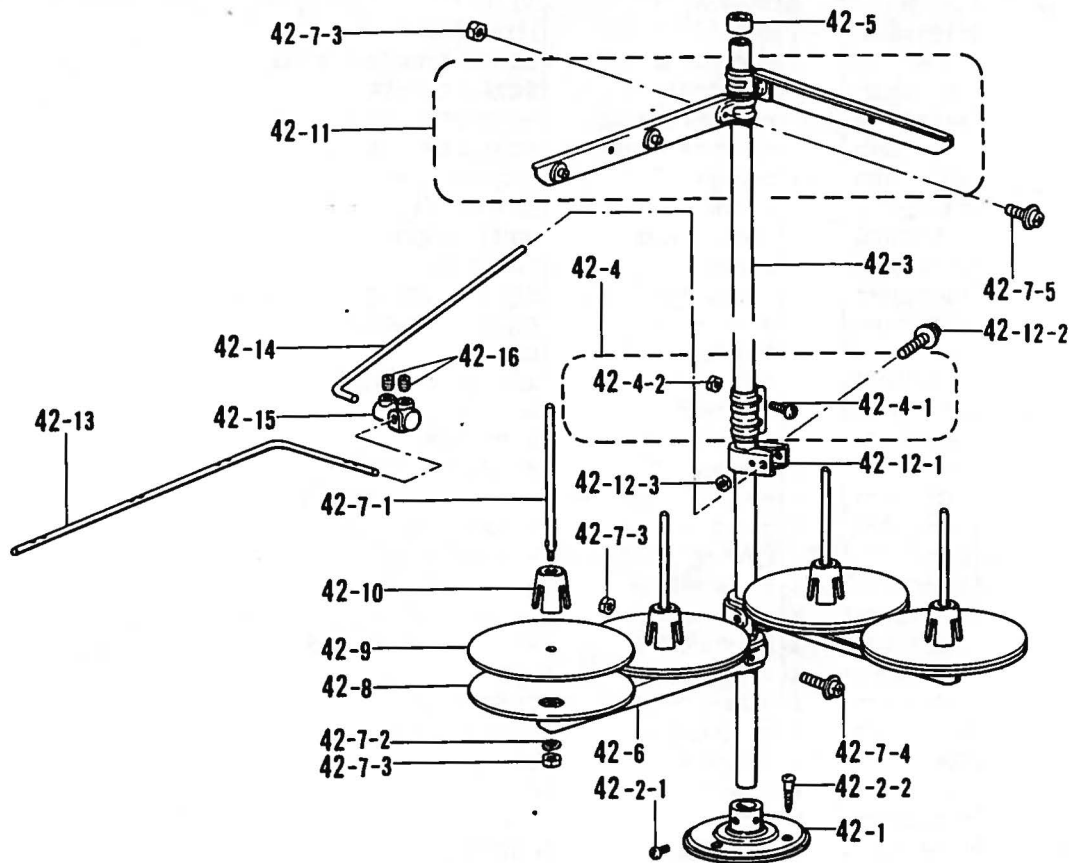

別売 /  
OPTION PARTS

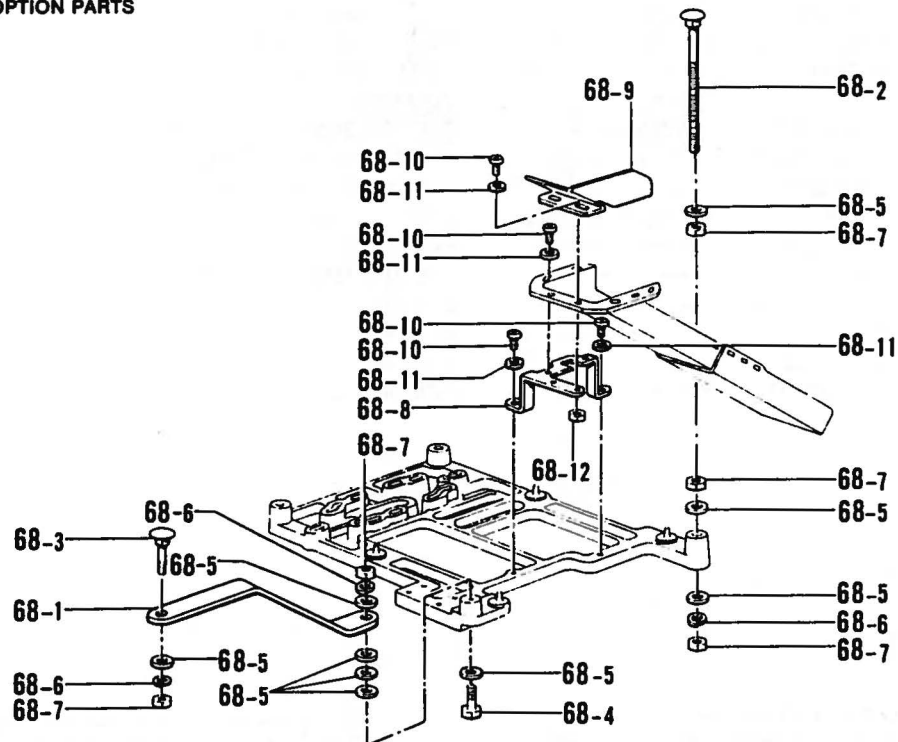



Z. 付属品関係 / Accessories / Zubehör / Accessoires / Accesorios

REF.NO.	CODE	Q'TY	ヒンメイ	NAME OF PARTS	RMKS
42	S02769109	1	イトタテタ"イクミ4THF	COTTON STAND ASSEMBLY 4THF	
42-1	150189009	1	ブラケット	COTTON STAND BASE	
42-2	S02773001	1	ブラケットネジ"セット	COTTON STAND BASE SCREW SET	
42-2-1	062060806	2	ナヘ"コ6X8	SCREW 6X8	
42-2-2	031452206	3	マルモク45X22	SCREW 45X22	
42-3	150172003	2	コラムパイプ	COLUMN PIPE	
42-4	150106003	1	コラムジョイントクミ	COLUMN JOINT ASSEMBLY	
42-4-1	062501406	2	ナヘ"コ5X14	SCREW 5X14	
42-4-2	021500106	2	1シユナツト5	NUT 5	
42-5	150174000	1	コラムキャップ	COLUMN CAP	
42-6	S02778002	2	スプールホルダー"2	SPOOL HOLDER 2	
42-7	S02780001	2	スプールネジ"セット2	SPOOL SCREW SET 2	
42-7-1	150179002	4	スプールシャフトB	SPOOL SHAFT B	
42-7-2	028050246	4	ハ"ネサ"カ"ネ2-5	SPRING WASHER 2-5	
42-7-3	021500106	8	1シユナツト5	NUT 5	
42-7-4	050503006	2	ナヘ"コヒラサ"5X30	SCREW 5X30	
42-7-5	050501406	2	ナヘ"コヒラサ"5X14	SCREW 5X14	
42-8	150180001	4	ウケサ"ラ	SPOOL STAND BASE	
42-9	150182000	4	スプールマット	SPOOL MAT	
42-10	126863001	4	スプールクッション	SPOOL CUSHION	
42-11	S02786002	2	スレット"ハンガー"クミ2	THREAD HANGER ASSEMBLY 2	
42-12	150145009	1	イトアンナイホルダー"クミ	THREAD GUIDE HOLDER ASSEMBLY	
42-12-1	150185009	1	イトアンナイホルダー"	THREAD GUIDE HOLDER	
42-12-2	050503006	1	ナヘ"コヒラサ"5X30	SCREW 5X30	
42-12-3	021500106	1	1シユナツト5	NUT 5	
42-13	142998001	1	イトアンナイ4	THREAD GUIDE 4	
42-14	S04109001	1	イトアンナイササエホ"ウ	THREAD GUIDE SUPPORTER BAR	
42-15	138843001	1	ササエホ"ウツキ"テ	JOINT	
42-16	014060632	2	アナトメ6X6クホ"ミ	SCREW 6X6	
<b>&lt;オプション/OPTION PARTS&gt;</b>					
68	S03886001	1	フルサブ"マーシ"セット	FULL SUBMERGED SET	
68-1	153319101	1	トウブ"ウケササエ	HEAD PLATE SUPPORTER	
68-2	153318101	3	カクネマルアタマホル"ルト	BOLT	
68-3	211964001	1	カクネホル"ルト8X55	BOLT 8X55	
68-4	017085502	1	ホル"ルトM8X55	BOLT 8X55	
68-5	025080236	15	ヒラサ"カ"ネチユウ8	WASHER 8	
68-6	028080242	5	ハ"ネサ"カ"ネ2-8	SPRING WASHER 2-8	
68-7	021080106	11	ナツト1シユ8	NUT 8	
68-8	S03889001	1	ダ"スター"シュー"トササエ	DUSTER SHOOT SUPPORTER	
68-9	S03890001	1	ダ"スター"ロツフ"	DUSTER DROP	
68-10	062681212	6	ナヘ"コ437-40X12	SCREW 437X12	
68-11	025680232	6	ヒラサ"カ"ネチユウ4.37	WASHER 4.37	
68-12	021680202	2	ナツト2シユ4.37	NUT 4.37	

※ 付属品の明細は変更することがあります。  
 ※ The details of included accessories are subject to change.  
 ※ Änderungen in der Aufstellung der Mitgelieferten Zubehöre sind vorbehalten.

※ Les détails des accessoires inclus sont sujets à des changements.  
 ※ Los detalles de los accesorios incluidos pueden variar.

仕機別部品一覧表 / DIFFERENT PARTS LIST / ZUBEHÖRLISTE /  
LISTE DES PIÈCES ACCESSOIRES / LISTA DE PIEZAS ACCESORIAS

SUB CLASS	サンショウ ハンゴウ REF.NO.	A-23	A-28	A-75	A-79	D-21	D-22	
	ヒンメイ PARTS シヨウ SPEC	ナヘ"コ437-40 X7 SCREW 437X7	マエカハ"ークミ FRONT COVER ASSEMBLY	オイルニガ"シグ"チ OIL CAP	シヨウラヘル LABEL	ハリト"メクミ NEEDLE CLAMP ASSEMBLY	ミシンハリ NEEDLE	
021-4	イッハンシ"ヌイヨウ  THIN	062680712	148993001	143196001	S19857001	146771001	147838011	
022-4	イッハンシ"ヌイヨウ				S19857003			
-5		↑	↑	↑	S19857004	146773001	151474011	
-6	THIN MEDIUM				S19857005			
-7					S19857006			
023-5	イッハンシ"ヌイヨウ				S19857007			
-6	(1ホ"ンハズ"シ)	↑	↑	↑	S19857008	↑	↑	
	THIN MEDIUM MOCK-SAFETY							
024-5	イッハンシ"ヌイヨウ				S19857010			
-6		↑	148995001	↑	S19857011	146775001	↑	
	THIN MEDIUM							
025-5	イッハンシ"ヌイヨウ				S19857013			
-6	(1ホ"ンハズ"シ)	↑	↑	↑	S19857014	↑	↑	
-7	THIN MEDIUM MOCK-SAFETY				S19857015			
026-4	ハ"ルキーニツトヨウ  BULKY KNIT	↑	148993001	↑	S19857016	146771001	147838011	
027-5	ハ"ルキーニツトヨウ				S19857019			
-6		↑	↑	↑	S19857020	146773001	151474014	
-7	BULKY KNIT				S19857021			
028-6	ハ"ルキーニツトヨウ				S19857023			
-7	(1ホ"ンハズ"シ) BULKY KNIT MOCK-SAFETY	↑	↑	↑	S19857024	↑	↑	

	サンショウ パンゴウ REF.NO.	A-23	A-28	A-75	A-79	D-21	D-22	
SUB CLASS	ヒンメイ PARTS	ナベ"コ437-40 X7 SCREW 437X7	マエカハ"ークミ FRONT COVER ASSEMBLY	オイルニカ"シク"チ OIL CAP	ショウラヘル LABEL	ハリト"メクミ NEEDLE CLAMP ASSEMBLY	ミシンハリ NEEDLE	
	ショウ SPEC							
031-7	デ"ニムヨウ  HEAVY	062680712	148995001	143196001	S19857025	146775001	151474018	
032-7	デ"ニムヨウ (1ホ"ンハズ"シ) HEAVY MOCK-SAFETY	↑	↑	↑	S19857026	↑	↑	
033-5	ラフリング"ヨウ  RUFFLING	↑	148993001	-----	S19857027	146773001	151474011	
034-5	ラフリング"ヨウ (1ホ"ンハズ"シ) RUFFLING MOCK-SAFETY	↑	↑	-----	S19857028	↑	↑	
037-5	ラフリング"ヨウ ハイピンク"ツキ RUFFLING W/PIPING	↑	↑	-----	S19857029	↑	↑	
041-5	テーピング"ヨウ  TAPING	↑	↑	143196001	S19857031	↑	↑	
045-5 -6 -7	ハ"ルキーニット テーピング"ヨウ BULKY KNIT TAPING	↑	↑	↑	S19857034 S19857035 S19857036	↑	151474014	
049-5	ハ"ックタック"ヨウ  BACK- TACKING	-----	↑	↑	S19857039	↑	151474011	
050-5	ハイピンク"ヨウ  PIPING	062680712	↑	-----	S19857041	↑	↑	



SUB CLASS	サンショウ パンゴウ REF.NO.	A-23	A-28	A-75	A-79	D-21	D-22	
	ヒンメイ PARTS	ナヘコ437-40 X7 SCREW 437X7	マエカハークミ FRONT COVER ASSEMBLY	オイルニガシグチ OIL CAP	シヨウラヘル LABEL	ハリトメクミ NEEDLE CLAMP ASSEMBLY	ミシンハリ NEEDLE	
シヨウ SPEC								
051-6 -7	ハルキニットヨウ BULKY KNIT	062680712	148993001	143196001	S19857042 S19857043	146773001	151474014	
056-6	ハインテングヨウ BINDING	↑	148999001	↑	S19857052	↑	151474011	
057-6 -7	ハルキニットヨウ BULKY KNIT	↑	148993001	↑	S19857054 S19857055	159878001	151474014	

SUB CLASS	サンショウ ハンゴウ REF. NO.	F-55	F-67	F-68	F-69	N-13	Z-1	
	ヒンメイ PARTS ショウ SPEC	レバーハネ LEVER SPRING	シュオクリハ MAIN FEED DOG	サトウオクリハ DIFFEREN- TIAL FEED DOG	ホシヨオクリハ CHAIN FEED DOG	クワルーハキコウクミ OVER LOOPER ASSEMBLY	ミシンハリ NEEDLE	
021-4	イッパンシヌイヨウ THIN	146560101	S09348101	S09349101	S13428001	144603301	147838011	
022-4 -5 -6 -7	イッパンシヌイヨウ THIN MEDIUM	↑	↑	S09350101	↑	↑ 146611301	151474011	
023-5 -6	イッパンシヌイヨウ (1ホンハズシ) THIN MEDIUM MOCK-SAFETY	↑	↑	↑	↑	144603301	↑	
024-5 -6	イッパンシヌイヨウ THIN MEDIUM	↑	↑	S13416001	↑	↑	↑	
025-5 -6 -7	イッパンシヌイヨウ (1ホンハズシ) THIN MEDIUM MOCK-SAFETY	↑	↑	↑	↑	146603301 ↑ 146611301	↑	
026-4	ハルキーニットヨウ BULKY KNIT	↑	S13190001	S13731001	S13429001	146611301	147838011	
027-5 -6 -7	ハルキーニットヨウ BULKY KNIT	↑	146745101	156131101	↑	↑	151474014	
028-6 -7	ハルキーニットヨウ (1ホンハズシ) BULKY KNIT MOCK-SAFETY	↑	↑	↑	↑	↑	↑	

SUB CLASS	サンショウ パンゴウ REF.NO.	F-55	F-67	F-68	F-69	N-13	Z-1	
	ヒンメイ PARTS	レバーハネ LEVER SPRING	シュオクリハ MAIN FEED DOG	サトウオクリハ DIFFEREN- TIAL FEED DOG	ホシヨオクリハ CHAIN FEED DOG	ウフルーパキコウクミ OVER LOOPER ASSEMBLY	ミシンハリ NEEDLE	
031-7	テニムヨウ  HEAVY	146560101	146790101	146791101	S13428001	146611301	151474018	
032-7	テニムヨウ (1ホムハズシ) HEAVY MOCK-SAFETY	↑	↑	↑	↑	↑	↑	
033-5	ラフリングヨウ  RUFFLING	↑	S13192001	S13417001	S13429001	146603301	151474011	
034-5	ラフリングヨウ (1ホムハズシ) RUFFLING MOCK-SAFETY	↑	↑	↑	↑	↑	↑	
037-5	ラフリングヨウ ハイピッキングツキ RUFFLING W/PIPING	↑	S13193001	↑	S13431001	↑	↑	
041-5	テーピングヨウ  TAPING	↑	S09348101	S09350101	S13428001	↑	↑	
045-5 -6 -7	ハルキーニット テーピングヨウ BULKY KNIT TAPING	↑	146745101	156131101	S13429001	146611301	151474014	
049-5	バックタックヨウ  BACK- TACKING	-----	S13191001	S13423001	S13428001	146603301	151474011	
050-5	ハイピッキングヨウ  PIPING	146560101	S13729001	-----	S13732001	↑	↑	



SUB CLASS	サンショウ ハンゴウ REF.NO.	F-55	F-67	F-68	F-69	N-13	Z-1	
	ヒンメイ PARTS ショウ SPEC	レバーハネ LEVER SPRING	シュオクリハ MAIN FEED DOG	サトウオクリハ DIFFEREN- TIAL FEED DOG	ホシオオクリハ CHAIN FEED DOG	クフルーハキコウクミ OVER LOOPER ASSEMBLY	ミシンハリ NEEDLE	
051-6 -7	ハルキニットヨウ BULKY KNIT	146560101	146745101	156037101	S13429001	146611301	151474014	
056-6	ハインテングヨウ BINDING	↑	S09348101	S13427001	S13428001	146603301	151474011	
057-6 -7	ハルキニットヨウ BULKY KNIT	↑	146745101	156037101	S13429001	S01428101	151474014	

索引/INDEX/VERZEICHNIS/  
INDEX/INDICE

CODE	REF.NO.	PAGE
S00049001	D - 14-1	8
S01223001	G - 1-1	24
S01248101	P - 13-1	38
S01295001	E - 39-1-6	14
	E - 39-11-6	18
	E - 39-13-6	18
	E - 39-2-6	14
	E - 39-3-6	14
	E - 39-6-6	16
S01297001	F - 73	22
S01304001	H - 2	30
S01417001	D - 19	8
S01428101	N - 13	36
S01431001	P - 11-2	38
S01432101	P - 13-3	38
S01465001	N - 15-4	36
S01471001	D - 32-2	8
S01597001	N - 9-2	36
S01614001	H - 1-1-31	26
	H - 1-2-31	28
	H - 1-3-29	30
S01652001	D - 14	8
S01654000	D - 14-2	8
S01675001	N - 23	36
S01706001	D - 36-10-1	10
	D - 36-2-1	10
	D - 36-3-1	10
	D - 36-4-1	10
	D - 36-8-1	10
S01707001	D - 36-13-1	10
	D - 36-14-1	10
S01708001	D - 36-10-2	10
	D - 36-11-2	10
	D - 36-13-2	10
	D - 36-14-2	10
	D - 36-2-2	10
	D - 36-3-2	10
	D - 36-4-2	10
	D - 36-8-2	10
S01711001	D - 36-3	10
S01713001	D - 36-4	10
S01715001	D - 36-8	10
S01717001	D - 36-10	10
S01719001	D - 36-13	10
S01721001	D - 36-14	10
S01860001	Z - 64	44
S01943001	Z - 7	44
S02769109	Z - 42	46
S02773001	Z - 42-2	46
S02778002	Z - 42-6	46
S02780001	Z - 42-7	46
S02786002	Z - 42-11	46
S02874001	C - 12-1-4	6
	C - 12-2-4	6
S03321001	E - 33	12
S03886001	Z - 68	46
S03887209	A - 62	4
S03888000	Z - 27	44
S03889001	Z - 68-8	46
S03890001	Z - 68-9	46
S04109001	Z - 42-14	46
S05837001	D - 36-16	10
S05838001	D - 36-17	10
S06294001	N - 6	36
S06561001	E - 4	12
S06701000	Z - 18	44
S06704001	Z - 39	44

CODE	REF.NO.	PAGE
S07201001	E - 39-7	16
S07202001	E - 39-8	16
S09133001	D - 36-2	10
S09232101	M - 1	34
S09233001	M - 1-1	34
S09234001	M - 1-2	34
S09235001	M - 1-3	34
S09237101	M - 1-6	34
S09240001	D - 26-2	8
S09323001	A - 84-1	4
S09324001	A - 84-2	4
S09348101	F - 67	22
S09349101	F - 68	22
S09350101	F - 68	22
S10774001	D - 18-2	8
	N - 14-2	36
S11072001	F - 8	20
S11101001	A - 84-3	4
S11109001	D - 28-2	8
S11110001	D - 36-11	10
S11111001	D - 36-11-1	10
S11117101	E - 39-11	18
S11121001	M - 10	34
S11144001	M - 1-5	34
S12677009	H - 1-2	26
S13190001	F - 67	22
S13191001	F - 67	22
S13192001	F - 67	22
S13193001	F - 67	22
S13416001	F - 68	22
S13417001	F - 68	22
S13423001	F - 68	22
S13427001	F - 68	22
S13428001	F - 69	22
S13429001	F - 69	22
S13431001	F - 69	22
S13729001	F - 67	22
S13731001	F - 68	22
S13732001	F - 69	22
S16176001	D - 34-3	8
S16496001	N - 15-5	36
S16498001	F - 1-1	20
S19857001	A - 79	4
S19857003	A - 79	4
S19857004	A - 79	4
S19857005	A - 79	4
S19857006	A - 79	4
S19857007	A - 79	4
S19857008	A - 79	4
S19857010	A - 79	4
S19857011	A - 79	4
S19857013	A - 79	4
S19857014	A - 79	4
S19857015	A - 79	4
S19857016	A - 79	4
S19857019	A - 79	4
S19857020	A - 79	4
S19857021	A - 79	4
S19857023	A - 79	4
S19857024	A - 79	4
S19857025	A - 79	4
S19857026	A - 79	4
S19857027	A - 79	4
S19857028	A - 79	4
S19857029	A - 79	4
S19857031	A - 79	4
S19857034	A - 79	4

CODE	REF.NO.	PAGE
S19857035	A - 79	4
S19857036	A - 79	4
S19857039	A - 79	4
S19857041	A - 79	4
S19857042	A - 79	4
S19857043	A - 79	4
S19857052	A - 79	4
S19857054	A - 79	4
S19857055	A - 79	4
S19901001	R - 12-1	42
S19901002	R - 12-2	42
S19901003	R - 12-3	42
S19901004	R - 12-4	42
S20130009	J - 1	32
S20131009	J - 1-1	32
S20134001	J - 1-1-1	32
S20135001	J - 1-1-2	32
013679412	H - 1-1-29	26
	H - 1-2-29	28
	H - 1-3-25	30
013760612	P - 10-1	38
013761410	B - 18	6
014060632	Z - 42-16	46
014680422	A - 87	4
	E - 29	12
	N - 13-7	36
	N - 15-1-1	36
	N - 15-2-1	36
	N - 15-3-1	36
	N - 15-5-1	36
	P - 14-1	38
	P - 14-2	38
014770622	F - 31	20
	Q - 2	40
	R - 2	42
014780622	H - 14-6	28
017085502	Z - 68-4	46
017771412	F - 36	22
	F - 44-2	22
	F - 52-1	22
	G - 11	24
	N - 3	36
017771612	A - 65	4
	D - 2	8
	E - 22	12
	F - 6	20
	F - 61	22
	G - 1-5	24
	P - 3	38
017781012	H - 14-10	28
	H - 14-13	28
	H - 14-4	28
018061622	D - 25	8
021080106	Z - 33	44
	Z - 68-7	46
021400106	Z - 21	44
021500106	Z - 42-12-3	46
	Z - 42-4-2	46
	Z - 42-7-3	46
021660102	E - 39-12-6	18
021670202	A - 50	2
021680202	Z - 68-12	46
025030132	E - 39-1-2	14
	E - 39-10-2	16
	E - 39-11-2	18
	E - 39-12-2	18
	E - 39-13-2	18

CODE	REF.NO.	PAGE
025030132	E - 39-14-3	18
	E - 39-2-2	14
	E - 39-3-2	14
	E - 39-4-2	14
	E - 39-5-2	14
	E - 39-6-2	16
	E - 39-7-3	16
	E - 39-8-3	16
	E - 39-9-2	16
025030232	Z - 61-3	44
025050236	Z - 59	44
025080236	Z - 31	44
	Z - 68-5	46
025350132	M - 2	34
025350332	L - 8	34
	Q - 3-2	40
025680232	Z - 68-11	46
025770232	F - 70	22
	H - 1-1-8	26
	H - 1-2-8	26
	H - 1-3-7	30
028050246	Z - 42-7-2	46
028080242	Z - 32	44
	Z - 68-6	46
031311302	Z - 37	44
031452206	Z - 42-2-2	46
032422505	H - 17-2	28
035412006	J - 1-2	32
047140842	A - 28-4	2
047300842	E - 6	12
047301440	N - 13-6	36
047502242	F - 58	22
048040342	F - 9	20
048080342	E - 19	12
048150143	F - 1-12	20
050501406	Z - 42-7-5	46
050503006	Z - 42-12-2	46
	Z - 42-7-4	46
060630312	R - 37	42
060660512	E - 36	12
060670512	A - 40	2
	A - 42	2
	H - 1-1-27	26
	H - 1-2-27	26
	H - 1-3-23	30
060680512	A - 29	2
	D - 27	8
	D - 29	8
062060806	Z - 42-2-1	46
062401406	Z - 22	44
062501406	Z - 42-4-1	46
062630812	F - 66-1	22
062660412	E - 38	12
	E - 39-12-1	18
	M - 11	34
	N - 5	36
	P - 5	38
	R - 16	42
	R - 22	42
	Z - 50	44
062660512	F - 1-8	20
	Z - 61-2	44
062660612	N - 16	36
062660712	F - 44-1	22
	F - 66-2	22
	H - 1-1-14	26
	H - 1-2-14	26



CODE	REF.NO.	PAGE
062670412	A - 28-7	2
062670512	L - 2	34
	L - 4	34
062670612	A - 20	2
	A - 26	2
	A - 31	2
	A - 48	2
	A - 61	4
	A - 71	4
	D - 35	8
	F - 11	20
	G - 20	24
	H - 13	30
	M - 9	34
	Q - 17	40
	R - 25	42
	R - 28	42
	R - 30	42
	R - 35	42
062670812	B - 5	6
	D - 10	8
	D - 33	8
	F - 19	20
	Q - 3-3	40
	R - 33	42
062671012	M - 3	34
	Q - 3-10	40
062671412	A - 49	2
062680612	H - 1-1-25	26
	H - 1-2-25	26
	H - 1-3-21	30
	L - 6	34
062680712	A - 23	2
	A - 52	2
	A - 8	2
	D - 18-1	8
	E - 14	12
	E - 30	12
	F - 33	20
	G - 23	24
	N - 14-1	36
062680812	H - 1-1-17	26
	H - 1-2-17	26
	H - 1-3-13	30
062681012	B - 14	6
	C - 2	6
	F - 25	20
	F - 28	20
	H - 17-1	28
	N - 13-5	36
	Z - 55-2	44
062681212	Z - 68-10	46
062681412	A - 4	2
062681612	G - 27-2	24
062711012	E - 34	12
062711212	Q - 4	40
071023850	N - 6-3	36
072600000	B - 4	6
072600100	B - 15	6
100025002	F - 1-17	20
100032003	A - 86	4
	D - 31	8
100080004	E - 39-1-3	14
	E - 39-10-3	16
	E - 39-11-3	18
	E - 39-13-3	18
	E - 39-14-4	18

CODE	REF.NO.	PAGE
100080004	E - 39-2-3	14
	E - 39-3-3	14
	E - 39-4-3	14
	E - 39-5-3	14
	E - 39-6-3	16
	E - 39-7-4	16
	E - 39-8-4	16
	E - 39-9-3	16
100136001	K - 1-4	32
100251001	F - 4	20
100260001	G - 5	24
	N - 12	36
100294002	F - 56	22
100366001	D - 1-3	8
	D - 7	8
	G - 1-3	24
100463001	H - 14-8	28
100645003	A - 53	2
	C - 15	6
	F - 24	20
	F - 27	20
	Z - 55-3	44
101118001	K - 2	32
	Z - 58	44
101572101	Z - 5	44
101706001	A - 38-1	2
	F - 22	20
	F - 34-1	22
	H - 1-1-18-1	26
	H - 1-1-4	26
	H - 1-2-32	28
	H - 1-2-4	26
	H - 1-3-14	30
	H - 1-3-3	30
	Q - 3-6-1	40
102627001	G - 14	24
102843004	A - 19	2
103978002	E - 39-12-5	18
105079001	D - 17	8
105161004	L - 7	34
105163001	H - 1-1-6	26
	H - 1-2-6	26
	H - 1-3-5	30
105216001	C - 13	6
105234003	H - 1-1-22	26
	H - 1-2-22	26
	H - 1-3-18	30
105248003	R - 23	42
105288001	E - 39-1-8	14
	E - 39-10-6	16
	E - 39-11-8	18
	E - 39-14-2	18
	E - 39-14-7	18
	E - 39-2-8	14
	E - 39-3-8	14
	E - 39-4-6	14
	E - 39-5-6	14
	E - 39-6-8	16
	E - 39-7-6	16
	E - 39-8-6	16
	E - 39-9-6	16
105343001	Z - 12	44
107244001	B - 12	6
107407003	G - 12	24
	G - 27-1	24
107682001	M - 1-8	34
107779001	Z - 10	44

CODE	REF.NO.	PAGE
108494001	K - 1-2	32
108495001	K - 1-3	32
108960002	A - 73	4
109203001	A - 67	4
	F - 57	22
110161006	E - 16	12
110230001	H - 1-1-21	26
	H - 1-2-21	26
	H - 1-3-17	30
110641002	A - 66	4
110668001	B - 9	6
110670000	B - 13	6
110672000	B - 16	6
110673000	B - 11	6
110704001	N - 4	36
	P - 4	38
110735002	L - 10	34
110793001	E - 18	12
110813001	R - 14-1	42
	R - 14-2	42
110820101	H - 1-1-7	26
	H - 1-2-7	26
	H - 1-3-6	30
	R - 4-1	42
	R - 4-3	42
110832009	R - 5	42
111486001	A - 24	2
	D - 30	8
112299001	R - 70	42
112300001	R - 68	42
112301001	H - 8-5	30
	R - 69	42
112348001	C - 3	6
	C - 6	6
	C - 9	6
	Q - 11	40
	Q - 19	40
	Q - 22	40
	Q - 24	40
	Q - 8	40
112359001	C - 10	6
	C - 4	6
	C - 7	6
	Q - 25	40
112364001	Q - 12	40
	Q - 20	40
	Q - 23	40
	Q - 9	40
112436001	G - 15	24
	Z - 4	44
112525000	Q - 58	40
112735000	Q - 51	40
112751002	H - 4	28
	Z - 52	44
113050001	G - 9-2	24
113431002	F - 76	22
113589001	A - 6	2
114294001	Q - 37	40
116016001	Z - 23	44
116794001	M - 1-7	34
117160001	A - 33	2
117466000	Z - 13	44
117515001	G - 16	24
117516001	F - 65-1	22
	F - 65-2	22
	G - 17	24
117517003	F - 1-16	20

CODE	REF.NO.	PAGE
118550001	A - 69	4
118770001	F - 75	22
122991001	Z - 25	44
123185001	A - 35	2
126863001	Z - 42-10	46
138843001	Z - 42-15	46
140066009	A - 55	4
140084000	B - 10	6
140088001	D - 1-2	8
140091000	D - 5	8
140092001	D - 6	8
140093000	D - 8	8
140096001	D - 9-2	8
140165001	F - 1-3	20
140176001	F - 1-15	20
140180001	B - 19	6
140187000	F - 18	20
140188004	F - 17	20
140205001	F - 35	22
140207001	F - 20-2	20
140208001	F - 20-3	20
	F - 20-8	20
	F - 40	22
140209001	F - 20-4	20
140210001	F - 20-5	20
140217001	F - 20-9	20
140232001	G - 1-2	24
140233001	G - 1-4	24
140235000	G - 6	24
140248001	G - 22	24
140261001	E - 21	12
140262000	E - 23	12
140263000	E - 24	12
140317000	Q - 47	40
140325001	Q - 15	40
140326009	F - 3	20
140327001	D - 4	8
	F - 14	20
	N - 6-2	36
	P - 7	38
	Z - 17	44
140342001	Q - 46	40
140415000	N - 13-4	36
140416000	Q - 48	40
140417000	Q - 41	40
140418000	A - 58	4
140421009	E - 35	12
140504001	E - 39-13-8	18
140530002	Z - 40	44
140759000	Q - 18	40
140778101	Q - 7	40
140779101	Q - 6	40
140780101	Z - 49	44
140888001	A - 37	2
141183000	H - 11	30
141514001	H - 8-2	30
	M - 5	34
	M - 7	34
142262001	Z - 24	44
142274009	B - 20	6
142669002	R - 36	42
142998001	Z - 42-13	46
143179000	B - 8	6
143196001	A - 75	4
143311001	B - 2	6
143312000	B - 3	6
143323103	E - 10-1	12



CODE	REF.NO.	PAGE
143325001	E - 12	12
143374001	A - 85	4
143564001	F - 37-1	22
143565001	F - 41	22
143566001	Z - 11	44
143767002	K - 1	32
143980001	K - 1-1	32
143992001	A - 9	2
144025001	N - 1	36
144029000	N - 8	36
144031000	N - 10	36
144044001	P - 1	38
144053001	F - 1-9	20
144055001	F - 1-10	20
144068001	F - 37-2	22
144073001	G - 26-1	24
144074100	G - 8-1	24
144075001	G - 9-1	24
144079001	E - 1	12
144081001	E - 3	12
144083001	E - 5	12
144085001	E - 8	12
144086001	E - 9	12
144091001	E - 39-7-2	16
	E - 39-8-2	16
144103009	R - 7	42
144104001	R - 8-1	42
144105000	H - 1-1-10	26
	H - 1-2-10	26
	H - 1-3-9	30
	R - 11	42
144108001	R - 21	42
144110001	R - 10	42
144111001	R - 26	42
144116000	C - 12-1-2	6
	C - 12-2-2	6
144117000	G - 7	24
144127001	D - 32-1	8
144179001	G - 26-3	24
144225002	Z - 41	44
144603301	N - 13	36
144619000	Q - 3-1	40
144622001	Q - 3-5	40
144764001	H - 1-1-26	26
	H - 1-2-26	26
	H - 1-3-22	30
144783001	H - 1-1-12	26
	H - 1-2-12	26
144784001	H - 1-1-13	26
	H - 1-2-13	26
144788001	H - 1-1-9	26
	H - 1-2-9	26
	H - 1-3-8	30
144793000	H - 3	28
	Z - 51	44
144816001	E - 39-7-1	16
	E - 39-8-1	16
145277105	Z - 19	44
145446001	R - 6	42
145663001	F - 1-2	20
145664000	Q - 32	40
145803001	H - 1-1-2	26
	H - 1-2-2	26
145807001	H - 1-1-16	26
	H - 1-2-16	26
	H - 1-3-12	30
145808001	H - 1-1-24	26

CODE	REF.NO.	PAGE
145808001	H - 1-2-24	26
	H - 1-3-20	30
145809001	H - 5	30
145810001	H - 1-1-19	26
	H - 1-2-19	26
	H - 1-3-15	30
145811001	H - 1-1-23	26
	H - 1-2-23	26
	H - 1-3-19	30
146315009	A - 57	4
146401001	F - 1-4	20
146402002	F - 1-5	20
146403001	F - 1-6	20
146404001	F - 1-7	20
146419009	A - 2	2
146420000	A - 3	2
146421000	A - 5	2
146422009	A - 7	2
146425009	A - 13	2
146426000	A - 14	2
146427001	A - 15	2
	D - 11	8
	D - 21-1	8
	M - 1-4	34
146428001	A - 16-1	2
146430001	A - 16-3	2
146432001	A - 17	2
146433000	A - 18	2
146436001	A - 25	2
146440001	A - 28-1	2
146441000	A - 28-2	2
146442001	A - 28-3	2
146443001	A - 30-2	2
146449001	A - 39	2
146450001	A - 41	2
146451001	A - 43	2
146452001	A - 44	2
146453001	A - 46	2
146454001	A - 47	2
146457001	A - 60	4
146460001	A - 70	4
146473001	B - 7	6
146476101	D - 1	8
146478001	D - 1-4	8
146479001	D - 3	8
146480001	D - 9	8
146482001	D - 9-3	8
146483001	D - 12	8
146494001	D - 26-1	8
146495001	D - 28-1	8
146511100	C - 1	6
146512101	C - 5	6
146515000	C - 8	6
146516000	C - 11	6
146521001	E - 2	12
146522001	E - 13-1	12
146523001	E - 17	12
146524001	E - 20	12
146525001	E - 25	12
146526001	E - 26-2	12
146527001	E - 28	12
146528101	F - 1	20
146529001	F - 1-11	20
146530001	F - 1-13	20
146531001	F - 1-14	20
146532001	F - 2	20
146533001	F - 5	20



CODE	REF.NO.	PAGE
146534001	F - 7	20
146536001	F - 10	20
146537000	F - 12	20
146538001	F - 13	20
146539000	F - 15	20
146540000	F - 16	20
146541001	F - 20-1	20
146544000	F - 20-1-2	20
146547000	F - 29	20
146548101	F - 30	20
146549001	F - 32	20
146550001	F - 44	22
146554001	F - 20-6	20
146555001	F - 20-7	20
146556001	F - 49	22
146558001	F - 53	22
146559001	F - 54	22
146560101	F - 55	22
146561001	F - 59-1	22
146562001	F - 59-3	22
146563001	F - 60	22
146564001	F - 62	22
146565001	F - 63	22
146566001	F - 64	22
146580001	G - 24	24
146581001	G - 4	24
	N - 11	36
146582001	G - 10	24
146583001	G - 13-2	24
146584001	G - 18	24
146585001	G - 19	24
146586009	G - 21	24
146587209	H - 1-1	26
146588001	H - 1-1-1	26
	H - 1-2-1	26
	H - 1-3-1	30
146589001	H - 1-1-3	26
	H - 1-2-3	26
	H - 1-3-2	30
146590001	H - 1-1-5	26
	H - 1-2-5	26
	H - 1-3-4	30
146592001	H - 1-1-28	26
	H - 1-2-28	26
	H - 1-3-24	30
146594001	H - 16	28
146602001	N - 9-1	36
146603301	N - 13	36
146611301	N - 13	36
146614001	P - 6	38
146615000	P - 8	38
146616000	P - 9	38
146617001	P - 11-1	38
146636201	Q - 13	40
146647001	Q - 1	40
146648001	R - 1	42
146649001	R - 3-1	42
146652001	R - 31	42
146653001	R - 32	42
146654001	R - 34	42
146700001	Z - 8	44
146706001	A - 16-2	2
146708000	A - 21	2
146709000	A - 22	2
146712001	A - 30-1	2
146713001	A - 32-1	2
146717109	A - 51	2

CODE	REF.NO.	PAGE
146724001	B - 1-1	6
146725002	D - 24	8
146738000	C - 12-1	6
146739000	C - 12-1-1	6
146740000	C - 12-1-3	6
	C - 12-2-3	6
146741000	F - 21	20
146742001	F - 59-2	22
146745101	F - 67	22
146754001	G - 13-1	24
146765001	A - 76	4
146771001	D - 21	8
146773001	D - 21	8
146775001	D - 21	8
146777201	D - 34-1	8
146778101	D - 34-2	8
146779001	D - 36-1	10
146785001	D - 36-9	10
146787001	C - 14-1	6
146788001	C - 14-2	6
146789001	E - 26-1	12
146790101	F - 67	22
146791101	F - 68	22
146793001	R - 15	42
146883001	E - 37	12
146887001	E - 39-1-4	14
	E - 39-10-4	16
	E - 39-11-4	18
	E - 39-13-4	18
	E - 39-14-5	18
	E - 39-2-4	14
	E - 39-3-4	14
	E - 39-4-4	14
	E - 39-5-4	14
	E - 39-6-4	16
	E - 39-9-4	16
146888002	E - 39-1-5	14
	E - 39-11-5	18
	E - 39-2-5	14
	E - 39-3-5	14
	E - 39-6-5	16
146903002	E - 39-11-1	18
146905001	E - 39-5-1	14
146907001	E - 39-10-1	16
	E - 39-4-1	14
146914001	F - 52	22
146924000	A - 32-1-1	2
	A - 32-2-1	2
146926002	R - 27	42
146929001	R - 29	42
146964001	E - 39-1-1	14
146966002	E - 39-6-1	16
147049001	R - 12-1-2	42
147049002	R - 12-2-2	42
147049003	R - 12-3-2	42
147049004	R - 12-4-2	42
147211101	Q - 21	40
147217000	Q - 31	40
147318000	Q - 52	40
	Q - 56	40
147344001	R - 67	42
147361000	Q - 53	40
147363000	Q - 55	40
147367001	A - 32-2	2
147371001	E - 39-14-1	18
147373000	L - 1	34
147377001	L - 3	34











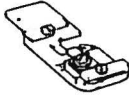















CODE	REF.NO.	PAGE
147440000	L - 5	34
147454001	E - 13-2	12
147480001	M - 4	34
147521001	Q - 3	40
147523001	Q - 3-4	40
147527001	Q - 3-7	40
147528100	Q - 3-8	40
147529001	Q - 3-9	40
147672001	H - 12	30
	M - 8	34
147773001	F - 20-1-1.	20
147838011	D - 22	8
	Z - 1	44
147848109	B - 17	6
147893009	Z - 20	44
147919001	Z - 48-1	44
147919002	Z - 48-2	44
147933001	H - 1-1-15	26
	H - 1-2-15	26
	H - 1-3-11	30
147934001	N - 15-1	36
147936001	N - 15-2	36
147943001	A - 83	4
148008000	C - 12-2	6
148009000	C - 12-2-1	6
148030001	D - 36-5	10
148031001	D - 36-6	10
148032001	D - 36-7	10
148033001	N - 6-1	36
148034001	N - 6-4	36
148042001	Z - 55-1	44
148084001	A - 54	2
148174000	F - 23	20
148281101	G - 25	24
148294001	N - 13-2	36
	N - 20	36
148341001	G - 26-2	24
148343101	G - 28	24
148344001	G - 29	24
148348009	Z - 55	44
148369101	E - 10-2	12
148370001	R - 3-2	42
148371001	M - 6	34
148372001	E - 11	12
148379001	N - 13-1	36
148387001	H - 1-2-18	26
	H - 1-3-26	30
148388001	H - 8-1	30
148389001	H - 8-3	30
148390001	H - 8-4	30
148391001	H - 10	30
148395001	H - 8	30
148425001	D - 1-1	8
	G - 1-1-1	24
	N - 1-1	36
	P - 1-1	38
148427001	G - 1	24
148430109	Z - 36	44
148431209	Z - 56-1	44
148432009	Z - 56-2	44
148782001	P - 15	38
148797001	H - 14-5	28
148798009	H - 14-7	28
148815001	G - 8-2	24
148834001	F - 50	22
148851001	R - 8-2	42
148984001	A - 28-5	2

























CODE	REF.NO.	PAGE
148993001	A - 28	2
148995001	A - 28	2
148999001	A - 28	2
149170001	D - 9-1	8
	N - 13-3	36
149171001	P - 12	38
149173001	Z - 9	44
149183001	E - 39-12-3	18
149192001	D - 36-12	10
149195101	E - 39-12	18
149197000	L - 9	34
149202209	H - 1-3	30
149203001	H - 1-3-27	30
149525001	E - 39-2-1	14
149526101	E - 39-9-1	16
149566009	H - 1-1-11	26
	H - 1-2-11	26
	H - 1-3-10	30
	R - 12-1-1	42
	R - 12-2-1	42
	R - 12-3-1	42
	R - 12-4-1	42
149886000	F - 71	22
149887001	F - 72	22
149888000	F - 26	20
150106003	Z - 42-4	46
150145009	Z - 42-12	46
150172003	Z - 42-3	46
150174000	Z - 42-5	46
150179002	Z - 42-7-1	46
150180001	Z - 42-8	46
150182000	Z - 42-9	46
150185009	Z - 42-12-1	46
150189009	Z - 42-1	46
150307000	Q - 42	40
150550000	Z - 61-1	44
150553002	H - 1-1-20	26
	H - 1-2-20	26
	H - 1-3-16	30
150556002	H - 6	30
150739001	E - 39-12-4	18
150866001	B - 1-2	6
150871001	E - 39-13-1	18
150872001	E - 39-13-5	18
151017001	Z - 61	44
151059001	A - 59	4
151060000	A - 64	4
151474011	D - 22	8
	Z - 1	44
151474014	D - 22	8
	Z - 1	44
151474018	D - 22	8
	Z - 1	44
152194001	A - 28-6	2
153318101	Z - 68-2	46
153319101	Z - 68-1	46
153483001	E - 15	12
154795001	H - 1-1-30	26
	H - 1-2-30	28
	H - 1-3-28	30
154829001	A - 34	2
154928000	C - 1-1	6
154969002	E - 39-1-7	14
	E - 39-10-5	16
	E - 39-11-7	18
	E - 39-13-7	18
	E - 39-14-6	18



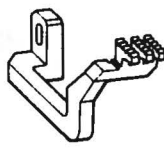







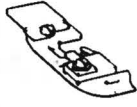









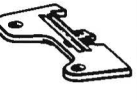









CODE	REF.NO.	PAGE
154969002	E - 39-2-7	14
	E - 39-3-7	14
	E - 39-4-5	14
	E - 39-5-5	14
	E - 39-6-7	16
	E - 39-9-5	16
154972001	E - 39-7-5	16
	E - 39-8-5	16
154985001	E - 39-5	14
154986101	E - 39-1	14
154987201	E - 39-6	16
154989001	E - 39-4	14
154998001	E - 39-13	18
155196209	H - 14	28
155197001	H - 14-1	28
155198101	H - 14-2	28
155199101	H - 14-3	28
155201101	H - 14-9	28
155202001	H - 14-11	28
155203201	H - 14-12	28
155205001	H - 15	28
156037101	F - 68	22
156131101	F - 68	22
156189001	E - 39-14	18
156191001	D - 36-15	10
156564001	E - 39-10	16
156565001	E - 39-2	14
156566101	E - 39-9	16
159101000	N - 18	36
159475001	F - 20	20
159476000	A - 63	4
159574101	R - 4-2	42
159636000	D - 20	8
159638001	D - 16	8
159639001	A - 72	4
159640000	A - 68	4
159686001	N - 15-3	36
159878001	D - 21	8
159884101	P - 13-2	38
159967101	E - 39-3	14
159968001	E - 39-3-1	14
180323001	P - 10	38
181969003	A - 38	2
	F - 34	22
181995001	Q - 3-6	40
181995002	H - 1-1-18	26
183161209	Z - 56	44
210973001	Z - 29	44
211964001	Z - 68-3	46



ゲージ部品 / GAUGE PARTS / TEILE DER LEHRE /  
PIECES DE JAUGE / PIEZAS DE CALIBRE

サブ クラス Sub-Class	一般地縫用 Thin 021-4	一般地縫用 Thin Medium 022-4 -5 -6 -7	一般地縫用 (1本外シ) Thin Medium (Mock-safety) 023-5 -6	一般地縫用 Thin Medium 024-5 -6 025-5	一般地縫用 (1本外シ) Thin Medium (Mock-safety) 025-6 -7	バルキーニット用 Bulky knit 026-4	バルキーニット用 Bulky knit 027-5 -6 -7
品名 Name of Parts							
オサエクミ Presser Foot Assembly	 154986-101	 156565-001		 159967-101 (-5) 154987-201 (-6)	 154987-201 (-6) (-7)	 154986-101	 154989-001 (-5) 154985-001 (-6) (-7)
ハリドメクミ Needle Clamp Assembly	 146771-001	 146773-001		 146775-001		 146771-001	 146773-001
ハリイタ (クミ) Needle Plate (Assembly)	 146779-001	 (S09133-001) (-4) (S01711-001) (-5) (S01713-001) (-6) (S01715-001) (-7)		 148030-001 (-5) 148031-001 (-6)	 148031-001 (-6) 148032-001 (-7)	 146779-001	 (S01711-001) (-5) (S01713-001) (-6) (S01715-001) (-7)
シュオクリバ Main Feed Dog		 S09348-101				 S13190-001	 146745-101
サドウオクリバ Differential Feed Dog	 S09349-101	 S09350-101		 S13416-001		 S13731-001	 156131-101
ホジョオクリバ Chain Feed Dog		 S13428-001				 S13429-001	

サブクラス Sub-Class	バルキーニット用 Bulky Knit (Mock-safety)	デニム用 Heavy	デニム用 (1本外シ) Heavy (Mock-safety)	ラフリング用 Ruffling	ラフリング用 (1本外シ) Ruffling (Mock-safety)	ラフリング用 (パイピング付) Ruffling (W/piping)	テーピング用 Taping
品名 Name of Parts	028-6 -7	031-7	032-7	033-5	034-5	037-5	041-5
オサエクミ Presser Foot Assembly	 154985-001 (6) (7)	 154987-201		 S07201-001		 S07202-001	 156566-101
ハリドメクミ Needle Clamp Assembly	 146773-001	 146775-001			 146773-001		
ハリイタ (クミ) Needle Plate (Assembly)	 (S01713-001) (-6) (S01715-001) (-7)	 146785-001		 (S01717-001)			 (S01711-001)
シュオクリバ Main Feed Dog	 146745-101	 146790-101		 S13192-001	 S13193-001		 S09348-101
サドウオクリバ Differential Feed Dog	 156131-101	 146791-101		 S13417-001			 S09350-101
ホジョオクリバ Chain Feed Dog	 S13429-001	 S13428-001		 S13429-001	 S13431-001		 S13428-001

サブクラス Sub-Class	バルキーニット用 (テーピング用) Bulky Knit Taping	バックタッキング用 Back-tacking	パイピング用 Piping	バルキーニット用 Bulky Knit	バイディング用 Binding	バルキーニット用 Bulky Knit
品名 Name of Parts	045-5 -6 -7	049-5	050-5	051-6 -7	056-6	057-6 -7
オサエクミ Presser Foot Assembly	 156564-001	 S11117-101	 149195-101	 154998-001	 156189-001	 154985-001 (-6) (-7)
ハリドメクミ Needle Clamp Assembly			 146773-001			 159878-001
ハリイタ (クミ) Needle Plate (Assembly)	 (S01711-001) (-5) (S01713-001) (-6) (S01715-001) (-7)	 (S11110-001)	 149192-001	 (S01719-001) (-6) (S01721-001) (-7)	 156191-001	 S05837-001 (-6) S05838-001 (-7)
シュオクリバ Main Feed Dog	 146745-101	 S13191-001	 S13729-001	 146745-101	 S09348-101	 146745-101
サドウオクリバ Differential Feed Dog	 156131-101	 S13423-001	—	 156037-101	 S13427-001	 156037-101
ホジョオクリバ Chain Feed Dog	 S13429-001	 S13428-001	 S13732-001	 S13429-001	 S13428-001	 S13429-001